

# FINAL REPORT

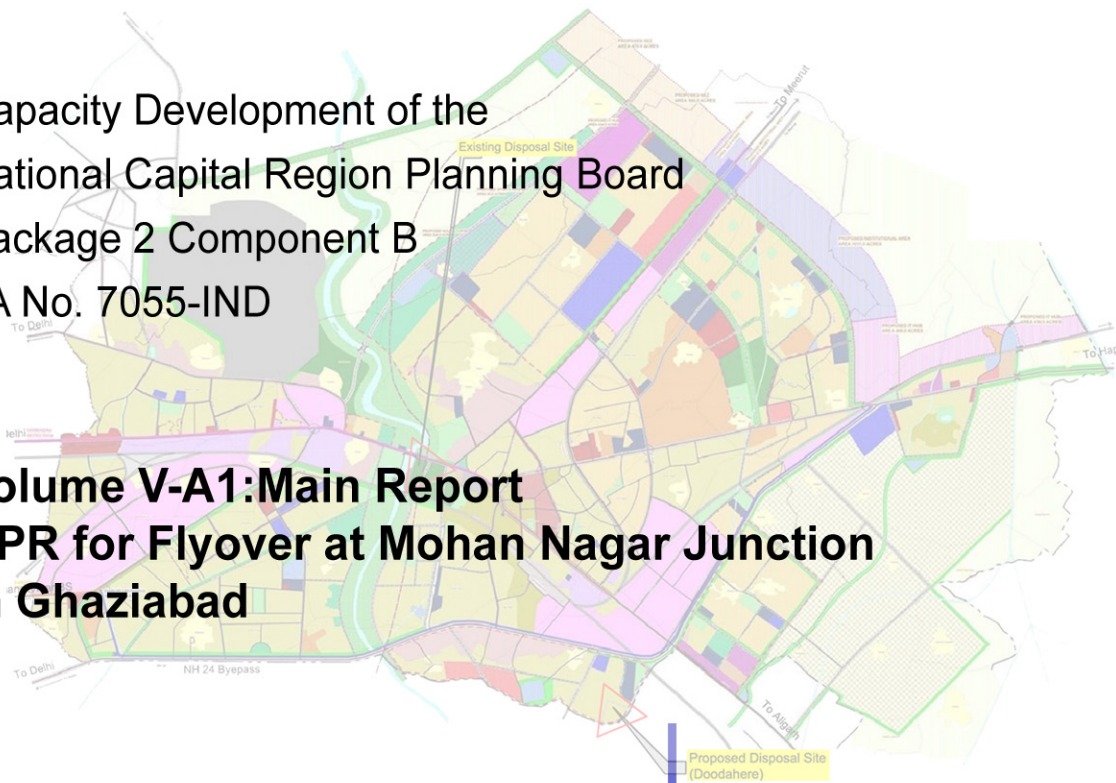
ADB



Asian Development Bank  
National Capital Region Planning Board

Capacity Development of the  
National Capital Region Planning Board  
Package 2 Component B  
TA No. 7055-IND

**Volume V-A1: Main Report  
DPR for Flyover at Mohan Nagar Junction  
in Ghaziabad**



**WilburSmith**  
ASSOCIATES

July 2010

NCR Planning Board  
Asian Development Bank

# Capacity Development of the National Capital Region Planning Board (NCRPB) – Component B (TA No. 7055-IND)

FINAL REPORT

Volume V-A1: DPR for Flyover at Mohan Nagar Junction in  
Ghaziabad

Main Report

July 2010

---



## Abbreviations

ADB	Asian Development Bank
DFR	Draft Final Report
DPR	Detailed Project Report
FR	Final Report
TA	Technical Assistance
NCR	National Capital Region
NCRPB	National Capital Region Planning Board
NH	National Highway
MORT&H	Ministry of Road Transport and Highways
BIS	Bureau of Indian Standard
IRC	Indian Road Congress
IS	Indian Standard
KMPH	Kilometer per Hour
SP	Standard Procedure
RCC	Reinforced Cement Concrete
CBR	California Bearing Ratio
LCV	Light Commercial Vehicle
MAV	Multi-axle Vehicle
CMSA	Cumulative number of Million Standard Axles
BC	Bitumen Concrete
DL	Dead Load
BOQ	Bill of Quantities
INR	Indian Rupees

## Contents

<b>1. INTRODUCTION .....</b>	<b>1</b>
A. BACKGROUND .....	1
B. OVERVIEW OF THIS ADB TA .....	2
C. ABOUT THE FINAL REPORT .....	3
D. STRUCTURE OF VOLUME V REPORT .....	4
1. <i>Structure of this Volume V-A Report</i> .....	4
<b>2. TRAFFIC SCENARIO.....</b>	<b>5</b>
A. TRAFFIC SCENARIO AT MOHAN NAGAR JUNCTION .....	5
<b>3. ENGINEERING SURVEYS &amp; INVESTIGATIONS .....</b>	<b>7</b>
A. GENERAL .....	7
B. TOPOGRAPHICAL SURVEYS .....	7
1. <i>Detailed Survey of Topographical Features</i> .....	7
C. TRIAL PIT/ SUBSOIL INVESTIGATIONS .....	8
1. <i>For Pavement Design</i> .....	8
2. <i>Soil Testing for Embankments</i> .....	11
D. GEO TECHNICAL INVESTIGATIONS FOR FOUNDATION OF STRUCTURE.....	11
E. MATERIAL SURVEY AND ANALYSIS .....	12
1. <i>Cement, Bitumen and Steel</i> .....	12
2. <i>Water Quality</i> .....	12
F. IDENTIFICATION OF UTILITIES .....	13
<b>4. IMPROVEMENT PROPOSALS AND DESIGN STANDARDS .....</b>	<b>14</b>
A. GENERAL .....	14
B. GEOMETRIC AND STRUCTURAL DESIGN STANDARDS .....	14
1. <i>Geometric Standards</i> .....	14
2. <i>Road Signage and Markings</i> .....	15
C. STRUCTURAL DESIGN STANDARDS .....	15
D. DETAILS OF IMPROVEMENT PROPOSALS.....	16
E. IMPROVEMENTS TO EXISTING TRAFFIC REGULATIONS.....	19
F. RIGHT OF WAY.....	19
G. SALIENT FEATURES OF PROPOSED FLYOVER.....	19
1. <i>Superstructure</i> .....	20
2. <i>Substructure</i> .....	20
3. <i>Foundation</i> .....	20
H. AT GRADE ROADS.....	20
I. UTILITY RELOCATION PLAN.....	21
<b>5. DESIGN REPORT .....</b>	<b>22</b>
A. GENERAL .....	22
B. STRUCTURAL ARRANGEMENT OF FLYOVER .....	22
C. AT GRADE ROADS.....	22
D. DESIGN METHODOLOGY .....	23
1. <i>Geometric Design Standards</i> .....	23
2. <i>Proposed Geometry</i> .....	23
E. PAVEMENT DESIGN .....	26
1. <i>Design of Flexible Pavement for New Pavement as per IRC: 37-2001</i> .....	26
2. <i>Existing Sub grade and Design CBR</i> .....	27
3. <i>Pavement Design</i> .....	28
4. <i>Structural Design Standards</i> .....	28
F. DESIGN OF SUPERSTRUCTURE .....	29
1. <i>Post tensioned Girders</i> .....	29
G. DESIGN OF SUBSTRUCTURE AND FOUNDATION .....	34
<b>6. BILL OF QUANTITIES COST ESTIMATES .....</b>	<b>38</b>

A. BILL OF QUANTITIES .....	38
B. RATES ANALYSIS .....	39
C. ESTIMATED COSTS .....	39

### **List of Tables**

<b>Table 2-1:</b> Projected Traffic at Mohan Nagar Junction.....	5
<b>Table 3-1:</b> Laboratory Test Results for Sub grade Area Soil .....	10
<b>Table 3-2:</b> Details of Existing Utilities.....	13
<b>Table 5-1:</b> Geometric Design Standards .....	23
<b>Table 5-2:</b> Summary of Horizontal Alignment Report.....	24
<b>Table 5-3:</b> Summary of Vertical Alignment Report.....	25
<b>Table 5-4:</b> Summary of Commercial Vehicles Average Daily Traffic (ADT) in 2008.....	26
<b>Table 5-5:</b> Estimated traffic at the end of construction period.....	27
<b>Table 5-6:</b> Cumulative number of Million Standard Axles (CMSA).....	27
<b>Table 5-7:</b> Proposed Design of Flexible Pavement for a Design Life Period of 15 Years.....	28
<b>Table 6-1:</b> Summary of Cost Estimates.....	39

### **List of Figures**

<b>Figure 2-1:</b> Projected Traffic at Mohan Nagar Junction .....	5
<b>Figure 2-2:</b> Location of Proposed Flyover .....	6
<b>Figure 2-3:</b> Orientation of Grade-Separator .....	6
<b>Figure 4-1:</b> Typical cross section of flyover .....	17
<b>Figure 4-2:</b> Typical cross section at pier .....	17
<b>Figure 4-3:</b> Plan at Pier .....	18
<b>Figure 4-4:</b> Typical Cross-section at Abutment .....	18
<b>Figure 4-5:</b> Plan at Abutment.....	19
<b>Figure 5-1:</b> Typical Cross Section showing layers of Pavement Composition.....	28
<b>Figure 5-2:</b> Typical End Girder Section.....	29
<b>Figure 5-3:</b> Typical Mid Girder Section.....	30
<b>Figure 5-4:</b> Grillage model for superstructure analysis.....	31
<b>Figure 5-5:</b> Details of Expansion Joint.....	37

### **List of Appendices**

**Appendix 1:** Geotechnical Investigation Report

#### **Compendium Volumes**

Besides this Volume V-A1, DPR for Mohan Nagar Flyover in Ghaziabad has following Volumes appended separately.

- Volume V-A2: Detailed Designs
- Volume V-A3: Detailed Drawings
- Volume V-A4: Detailed Estimates
- Volume V-A5: Financial & Economic Analysis
- Volume V-A6: Initial Environmental Examination
- Volume V-A7: Resettlement Plan

## 1. INTRODUCTION

### A. Background

1. The National Capital Region Planning Board, constituted in 1985 under the provisions of NCRPB Act, 1985, is a statutory body functioning under the Ministry of Urban Development, Government of India. NCRPB has a mandate to systematically develop the National Capital Region (NCR) of India. It is one of the functions of the Board to arrange and oversee the financing of selected development projects in the NCR through Central and State Plan funds and other sources of revenue.
2. On Government of India's request, Asian Development Bank (ADB) has formulated the technical assistance (TA) to enhance the capacities of National Capital Region Planning Board and its associated implementing agencies. The TA has been designed in three components: Component A relates to improving the business processes in NCRPB; Component B relates to improving the capacity of the implementing agencies in project identification, feasibility studies and preparing detailed engineering design; and Component C relates to urban planning and other activities.
3. ADB has appointed M/s Wilbur Smith Associates to perform consultancy services envisaged under Component B. In the context of this contract, the first deliverable – Inception Report, was submitted in October 2008. The second deliverable – Interim Report comprising Master Plan for sewerage in Hapur, Master Plan for Water Supply for Panipat, Master Plan for Drainage for Hapur, Master Plan for Solid Waste management for Ghaziabad, Traffic and Transport analysis for Ghaziabad, Socio-Economic base line survey result in 3 sample project towns and proceedings of workshop 1 was submitted in January 2009. The four Master Plans as stated above are also made available on NCRPB web site for use of the implementing agencies.
4. The third deliverable Draft Final Report (DFR) comprising Detailed Project Report (DPR) for water supply in Panipat, DPR for sewerage in Hapur, DPR for drainage in Hapur, DPR for drainage in Sonipat, DPR for solid waste management in Ghaziabad, DPR for four selected transport components (Flyover, Road widening, Multi-level Parking and Bus Terminal) in Ghaziabad, and a Report on Capacity Building Activities were submitted.
5. Now, this is the Final Report (FR) and is the fourth and final deliverable. The comments/feedback on Draft Final Report received from ADB, NCRPB and respective implementing agencies were duly incorporated and final DPRs for components of Water Supply, Sewerage, Drainage, Solid Waste Management, and Transport are submitted as part of this Final Report. This is the Detailed Project Report for Transport Component of Flyover (at Mohan Nagar Junction) in Ghaziabad.

## B. Overview of this ADB TA

6. *Objectives.* The objective of this TA is to strengthen the capacity at NCRPB, state-level NCR cells, and other implementing agencies in the area of planning for urban infrastructure and to impart necessary skills to conceive, design, develop, appraise and implement good quality infrastructure projects for planned development of NCR. The increased institutional capacity of the NCRPB and the implementing agencies will lead to effective and time scaling-up of urban infrastructure to (i) improve quality of basic urban services in the NCR; (ii) develop counter magnet towns; (iii) reduce in migration into Delhi and orderly development of NCR; and (iv) accelerate economic growth in the NCR.
  
7. The TA – Capacity Development of the NCRPB, Component B focuses on strengthening the capacities of NCRPB and implementing agencies relating to project feasibility studies and preparation, and detailed engineering design in the implementing agencies. Specifically, this component B of the TA will support the project preparation efforts of the implementing agencies by preparing demonstration feasibility studies that include all due diligence documentation required for processing of the project in accordance with best practices, including ADB’s policies and guidelines.
  
8. *Scope of Work.* According to the terms of reference of the TA assignment, the following activities are envisaged in component B of the TA:
  - (i) Conduct technical, institutional, economic and financial feasibility analysis of identified subprojects in the six sample implementing agencies;
  - (ii) Conduct safeguards due diligence on the subprojects, including environmental assessment report and resettlement plan for all subprojects covered in the sample implementing agencies;
  - (iii) Prepare environmental assessment framework and resettlement framework; and
  - (iv) Develop a capacity building and policy reform program for the implementing agencies, including governance strengthening, institutional development and financial management.
  
9. Besides, this component of the TA will also:
  - (i) help in assessing the current practices and procedures of project identification and preparation of detailed project reports including technical, financial, economic and social safeguard due diligence;
  - (ii) support preparation of standard procedure manuals for project identification and preparation of detailed project reports including technical, financial, economic and social safeguard due diligence;
  - (iii) train the implementing agencies in the preparation of detailed project reports by using the sample subprojects, reports on deficiency of current practices and standard protocol manuals; and
  - (iv) help in developing a user-friendly web-page where different manuals and guidelines

for preparation of DPRs will be made available for the implementing agencies.

### C. About the Final Report

10. At Interim Report stage of the TA, the Master Plans for Water Supply in Panipat, Sewerage system in Hapur, Drainage for Hapur and Municipal Solid Waste Management for Ghaziabad were prepared. The Master Plans provided 100 percent coverage of population and the area likely to be in planning horizon year 2031/2041. All works required up to planning horizon year were conceptualized, broadly designed and block cost was estimated. The Master Plans also provided phasing of investment such that under phase 1 works required to cover present spread of city were proposed.
11. At draft final report stage of the TA the Detailed Project Reports (DPRs) were prepared for Phase 1 works as suggested in the Master Plans. For preparation of DPRs, engineering surveys and investigations were conducted and various possible and feasible alternatives evaluated. Finally for the selected options the DPRs prepared with detailed designs, item wise detailed cost estimate, work specifications, implementation process and proposed implementation arrangements. Further, according to ADB procedures these DPRs in addition to technical analysis included institutional, financial and economic feasibility analysis and environmental and social safeguards due diligence – environmental assessment and resettlement plans.
12. The DPR's submitted as part of Draft Final Report was reviewed by the implementing agencies, NCRPB and the ADB. Now this Final Report comprising DPR's modified in light of comments of IA's is being submitted. The draft DPR for water supply in Panipat was reviewed by PHED Haryana. Detailed discussions were held with Superintending Engineer (Urban), Executive Engineer (Urban), Superintending Engineer (Karnal) and Executive Engineer Panipat. The comments made by PHED have been suitably incorporated in this Final Report.
13. These DPRs are proposed to be made available to the ULBs and other implementing agencies of the state governments as model DPRs so that they may replicate the methodology/approach in the future DPRs prepared by them for obtaining finances from the NCRPB.
14. *Organization of this Final Report.* The Final Report of the TA Component B is organized in following Seven Volumes:

**Volume I:** Detailed Project Report for Water Supply System in Panipat

**Volume II:** Detailed Project Report for Rehabilitation and Augmentation of Sewerage System in Hapur

**Volume III:** Detailed Project Report for Rehabilitation of Major Drains in Hapur

**Volume IV:** Detailed Project Report for Improvement of Solid Waste Management System in Ghaziabad

**Volume V:** Detailed Project Reports for Four Transport Components in Ghaziabad

**Volume VI:** Detailed Project Reports Rehabilitation of Drainage in Sonipat

**Volume VII:** Capacity Building Activities

**D. Structure of Volume V Report**

15. The DPRs for all four transport components are compiled in Volume V. This is Volume V is presented **four** volumes:

- (i) **Volume V-A:** DPR for Mohan Nagar Flyover
- (ii) **Volume V-B:** DPR for Road Widening
- (iii) **Volume V-C:** DPR for Bus Terminal
- (iv) **Volume V-D:** DPR for Multi-level Parking

*1. Structure of this Volume V-A Report*

16. This DPR for Mohan Nagar Flyover in Ghaziabad is compiled in following seven sub-volumes (**Volumes V-A1 to V-A7**) including this Main Report:

**Volume V-A1:** Main Report:

- **Section 1** Introduction
- **Section 2** presents traffic scenario at Mohan Nagar Junction
- **Section 3** provides details of engineering surveys and investigations carried out
- **Section 4** presents details on the proposed improvements and design standards
- **Section 5** presents detailed design
- **Section 6** presents estimate and costing

**Volume V-A2:** Detailed Designs

**Volume V-A3:** Detailed Drawings

**Volume V-A4:** Detailed Estimates

**Volume V-A5:** Financial & Economic Analysis

**Volume V-A6:** Initial Environmental Examination

**Volume V-A7:** Resettlement Plan

## 2. TRAFFIC SCENARIO

### A. Traffic Scenario at Mohan Nagar Junction

17. Patel Chowk (Mohan Nagar Junction) intersection on NH 24 is one of the critical locations that carry a high volume of traffic. The speed survey conducted on this stretch of the highway also indicated a peak hour average speed of 19 kmph. The study has mandated a flyover to be built at this junction (NH24/Madan Mohan Malviya/Loni Road) by 2015. Location and proposed orientation of flyover is presented in **Figure 2** and **Figure 3**.
18. From the traffic analysis carried out, it can be seen that a flyover is mandated at this location in 2015.

**Table 2-1:** Projected Traffic at Mohan Nagar Junction

S. No	Year	PCU
1	2010	6,867
2	2015	9,299
3	2020	11,893
4	2025	13,816
5	2030	14,632

**Figure 2-1:** Projected Traffic at Mohan Nagar Junction

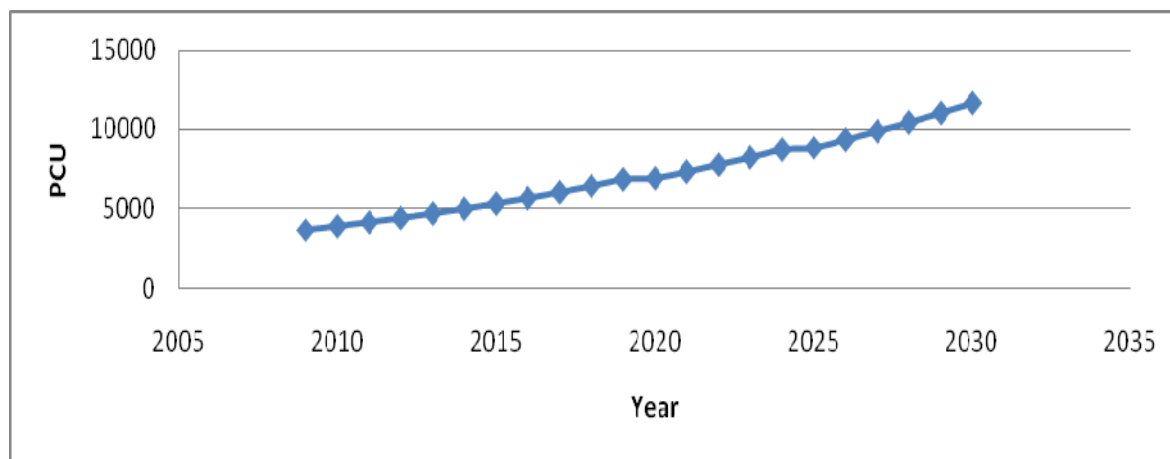


Figure 2-2: Location of Proposed Flyover

### Existing and Proposed Flyover Locations

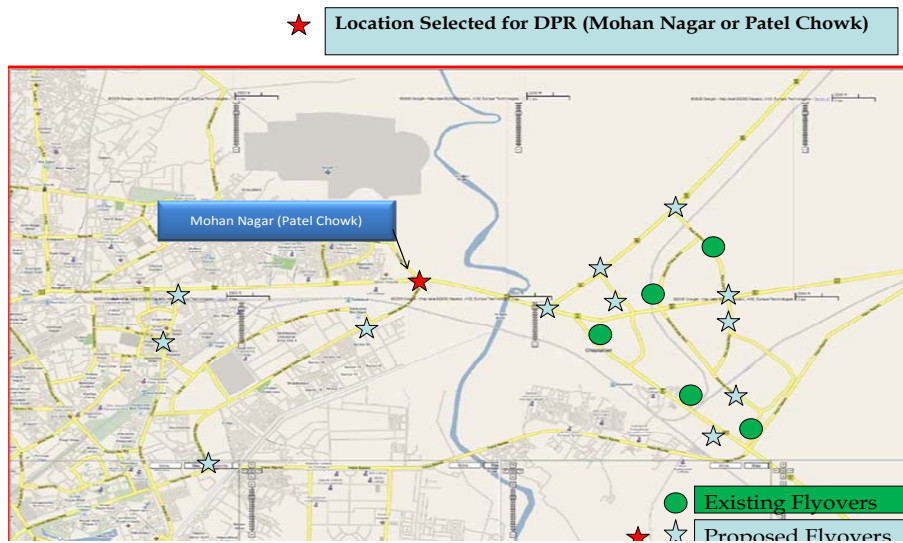


Figure 2-3: Orientation of Grade-Separator



### 3. ENGINEERING SURVEYS & INVESTIGATIONS

#### A. General

19. Various engineering surveys have been carried out for the proper planning and design of the grade separator at the proposed junction. Following surveys have been carried out:
- Topographical survey
  - Trial pit/subsoil investigations
  - Geotechnical investigations for foundations
  - Material survey

#### B. Topographical Surveys

20. The basic objective of the topographic survey was to collect the essential ground features of the proposed junction using Total Station to develop a Digital Terrain Model (DTM), to take care of design requirements of grade separated facility, identifying areas of restriction and their remedies. The data collected will result in the final design and is also used for the computation of earthwork and other quantities required.
21. As first step of the field study, satellite imagery maps of the location were collected and examined thoroughly to have first hand information about the area and to decide on the possible improvement options. It also helped out in finalizing the extent of topographical survey.
1. *Detailed Survey of Topographical Features*
22. Topographical survey using total station has been carried out to collect sufficient data to form the digital terrain model and to prepare the map of the physical features of the area. Following existing features have been captured during the survey:

- Building lines, type of buildings (shops or houses, number of stories), trees and Right of Way boundary if available at site by presence of boundary stones.
- Road edges, centerline, shoulders/footpaths, median etc
- Identifying all religious places, its locations, boundary lines and clear dimensions of compound walls and entrances.
- All service lines both above and below ground such as OFC cables, water and sewer pipes, gas pipes, electrical poles and cables, telephone poles and lines etc.
- Location of traffic islands, median, rotaries, dividers etc.
- Location of road side drains, clearly identifying the type (open/close), width of

drain, including the beginning and end of drains.

- Positions of transformers, mast, towers etc
- Apart from the above, the names of intersecting roads and other landmarks are also recorded and incorporated in the drawing.

23. Topographic survey was carried out using Total Station of 5-sec accuracy for detailed mapping and with higher accuracy total station during the traversing (min 3 sec). As part of the survey, the following activities were carried out

(i) Installation of Bench Mark Pillars: As first step of the survey, Bench mark pillars were installed as described below:

Bench mark pillars were constructed at every 250m interval. The pillars are in the form of concrete blocks of size 15 X 15 X 45 cm with a nail fixed at the center of the top surface were embedded up to a depth of 30cm in to the ground. The BM pillars were painted in yellow and details such as BM number and reduced level were clearly marked. Logical numbering sequence was followed.

(ii) Cross – Sections: Cross sections along the road have been taken at every 10 m interval in longitudinal direction for a minimum width of 15m or up to the building lines from the centerline of the existing carriageway on either side of the road. Cross section levels were taken at

- Centerline of existing carriageway and median edges
- Points between centerline and edge of carriageway
- Shoulder/Footpath edges/carriageway edges
- Additional points at locations of change in ground/critical points

(iii) Longitudinal Section: Longitudinal section levels along the centerline were taken at every 10m interval. Where curves or important features were encountered, this interval was suitably reduced. Cross sections points for the required width was taken corresponding to each point in the longitudinal section.

(iv) Map Plotting: The existing features surveyed were directly imported into Computer Aided Software and the details of the same has been plotted and presented for ready reference.

## C. Trial Pit/ Subsoil Investigations

### 1. For Pavement Design

24. *Objective*. The objective of the investigations is to provide basis for design of pavement for the service roads keeping in view the composition and characteristics of the existing pavement/sub grade. The scope of work, thus, includes collection of information regarding the existing pavement crust composition and characteristics and existing sub grade type and sub-soil conditions.

25. *Sub-grade Soil Testing.* Necessary sub soil investigations to understand the physical particulars of soil at site to enable proper pavement designs were carried out. All investigations were executed in conformation with IRC, BIS codes and MORT&H specifications. Test pits were taken along the road stretch at specified locations for the evaluation of physical properties of the sub grade soil to enable pavement design. The size of the test pit was kept as 1m x 1m x 1m. The representative samples of excavated soil from each trial pit at depth intervals GL to 0.25m, 0.25m to 0.5m, 0.5m to 0.75m and 0.75m to 1m were collected in airtight bags and properly packed and were sent to the laboratory for the required laboratory tests on these samples. The following tests were carried out to ascertain the properties of the sub-grade, base and sub-base layers of the existing road including thickness of different layers of pavement.

- Grain Size Analysis
- Atterberg Limits
- Modified Proctor
- CBR Values
- Field Density and Moisture Content

**Table 3-1:** Laboratory Test Results for Sub grade Area Soil

TP No	Depth (m)	Sieve & hydrometer analysis				LL %	PL %	Optimum Moisture Content %	Max. Dry Density g/cm3	CBR value %	G	$\pi d$ g/cm3	NMC %
		Gravel Content %	Sand Content %	Silt Content %	Clay Content %								
		1	GL-0.25	5	53								
1	0.25-0.50	2	57	41	0	N -	P	9.5	1.91	8.4	2.64	1.56	4.62
1	0.50-0.75	4	58	38	0	N -	P	9.2	1.88	8.6	2.62	1.54	4.48
1	0.75-1.00	2	59	39	0	N -	P	9.4	1.92	8.5	2.63	1.55	4.56
2	GL-0.25	4	53	43	0	N -	P	9.7	1.87	8.2	2.61	1.49	4.66
2	0.25-0.50	3	52	45	0	N -	P	9.5	1.92	8.4	2.6	1.51	4.55
2	0.50-0.75	7	48	45	0	N -	P	10.1	1.92	8.7	2.65	1.54	5.06
2	0.75-1.00	7	58	35	0	N -	P	9.3	1.925	8.7	2.63	1.56	5.12
3	GL-0.25	5	56	39	0	N -	P	9.5	1.89	8.2	2.64	1.5	4.3
3	0.25-0.50	4	55	41	0	N -	P	9.1	1.89	8.5	2.62	1.52	4.8
3	0.50-0.75	2	55	43	0	N -	P	9.9	1.9	7.7	2.65	1.54	5.45
3	0.75-1.00	3	54	43	0	N -	P	9.6	1.86	8.1	2.64	1.5	5.35
4	GL-0.25	0	54	46	0	N -	P	9.8	1.88	8.3	2.64	1.54	5.42
4	0.25-0.50	0	58	42	0	N -	P	9.2	1.89	7.9	2.63	1.54	4.35
4	0.50-0.75	0	57	43	0	N -	P	9.3	1.92	8.3	2.62	1.55	5.66
4	0.75-1.00	2	60	38	0	N -	P	9.1	1.94	8.6	2.62	1.54	4.38
5	GL-0.25	3	52	45	0	N -	P	9.7	1.875	8.3	2.64	1.54	5.35
5	0.25-0.50	3	53	44	0	N -	P	9.7	1.86	8.2	2.63	1.56	5.62
5	0.50-0.75	0	62	38	0	N -	P	9.1	1.93	8.8	2.62	1.49 1.54	4.38 4.62
5	0.75-1.00	2	52	46	0	N -	P	9.6	1.86	8.4	2.64	1.56	5.14

## 2. *Soil Testing for Embankments*

26. Additional tests were performed on identified borrow area materials, located at reasonable distance from the project site to ensure suitability of fill material and stability of embankment. Investigations to locate borrow areas for soil preceded the testing programmed. Test pits were excavated in borrow areas from where material for embankment was collected. The depth of each test pit did not exceed the likely depth of the borrow pit by more than 15 cm as per clause 10.3.2 of IRC –19. Samples of soil to be used in embankment were tested in the laboratory for the following properties

- Sieve Analysis
- Liquid Limit / Plasticity Index
- Moisture Content - dry density relationship using modified Proctor's Compaction
- Soaked CBR at Modified Proctor Density

27. The tests mentioned above are being carried out in accordance with the procedures laid down in IS 2720 "Methods of Tests for Soils." The test results of soil samples are presented as per IS: 1498-1959. In addition to tests already mentioned, samples of soil to be used in the top 50 cm of the embankment shall be tested in the laboratory for determination of C.B.R. Value at 100 per cent standard Proctor Density and Optimum Moisture Content, soaking the samples in water for 96 hrs. Samples of similar materials shall be molded at different densities by giving different number of blows namely 25, 45, 55 and 65 following modified Proctor's Compaction test procedure in a C.B.R mould and soaked C.B.R. tested at different densities to develop Density Vs C.B.R curve. From this curve C.B.R. at 98% modified Proctor Density shall be worked out. The C.B.R at 98% modified Proctor Density shall be used for the design of pavement as per IRC: 37-2001 "Guidelines for the Design of Flexible Pavement".

## D. **Geo Technical Investigations for Foundation of Structure**

28. The geotechnical investigations were carried out to appreciate the subsoil layers and their properties to facilitate finalizing the foundation type, depth, size and configuration. Subsoil condition is analyzed along with evaluation of field and laboratory data for determination of necessary physical and chemical characteristic of the in-situ soil strata. Bore holes were taken at four locations within the stretch where pier/foundations are planned. The bore logs details, test results and recommendations are given in **Appendix 1** (Geotechnical Investigation Report).

29. *Objective.* The objective of Geo-technical Investigations is to evaluate the following:

- To ascertain the sub-soil strata at foundation locations
- To study standing Ground Water Level
- To study the physical and engineering properties of soil strata and rock strata (if encountered).

- To evaluate allowable safe bearing capacity and settlements of soils/rock to design foundations for structure.
  - To recommend type and depth of foundation
  - To recommend improvements to the weak soil strata if any.
30. *Scope and Methodology of the Work.* The scope of work includes taking bore holes at the proposed flyover location and conducting the following Field (in situ) investigations and Laboratory Tests.
31. *Field (In-situ) Investigations.*
- (i) Drilling bore holes of 150 mm diameter to a maximum depth of 25m or minimum of 3m in rock if rock is encountered earlier.
  - (ii) Collecting disturbed and undisturbed soil samples at regular depth intervals
  - (iii) Conducting field-testing such as Standard Penetration Tests as per IS 2131-1981 at every 1.5m depth intervals or wherever strata change is observed to determine N values as well as relative density and stiffness of the soil strata.
  - (iv) To study and record the standing Ground Water Table Level.
  - (v) To ascertain the sub-soil strata and ground topography.
32. All the details of geotechnical investigations are presented in the geotechnical report.

## **E. Material Survey and Analysis**

33. As part of material investigation, source of construction materials like sand, aggregates etc have been identified. The approved quarry details have been collected from the UP PWD. Information on the source of construction materials and their properties were also collected from the sites where construction work is under progress. Accordingly, it was understood that, Yamuna Nagar in Haryana about 200 km away is a known source for stone aggregates, Ghaghar, 180 km away and Haridwar, 160 km away are sources for sand and Noida, 30 km away for soil.

### *1. Cement, Bitumen and Steel*

34. Cement and steel with IS certification are available in abundance from the local market or can be purchased from the manufacturers. Bitumen of 80/100, 60/70, 30/40-penetration grades, Crumb Rubbiser Modified Bitumen - 55 grade and Polymer Modified Bitumen SBS 70 grade are available from HPCL and HINCOL in Delhi.

### *2. Water Quality*

35. Water used for construction shall be potable. Potable water is available around 1 km away the junction location.

**F. Identification of Utilities**

36. During site studies, the presence of following utilities in the area of proposed development has been identified.

**Table 3-2: Details of Existing Utilities**

<b>S. No</b>	<b>Utilities</b>	<b>Number</b>
1	Lamp post	33
2	Transformer	7
3	Telephone pole	1
4	Tree	36
5	Man hole	22
6	Electric pole	51

#### 4. IMPROVEMENT PROPOSALS AND DESIGN STANDARDS

##### A. General

37. The junction caters for highly congested and crammed traffic throughout the day especially during peak hours. Based on the results of the surveys and investigations described in chapter 2 and 3 an arrangement best suiting to the traffic pattern is proposed for improving the situation. Proposal is evolved giving due consideration to minimize land acquisition. All the site constraints have been taken care while formulating the improvement scheme. The main objective is to improve the present state of affairs immensely and make the movement of traffic manageable to the possible extend, though a fully conflict free situation cannot be realized.

##### B. Geometric and Structural Design Standards

38. Geometry of NH 24 has a mild curve in this stretch and hence the elevated structure also follows a geometry having mild curve.
39. As this project road falls within urban limits, relevant IRC design standards with due consideration to the latest directive and guidelines of MOSRTH/IRC were followed, as far as possible, while formulating the design standards. Other National and International standards were also referred to wherever found relevant. Standards for the various components are briefed below.

###### 1. Geometric Standards

- IRC: 86 – 1983, “Geometric Design Standards for Urban Roads in Plains”.  
IRC: 92-1985, “Guidelines for the design of interchanges in Urban areas”
40. *Design Speed:* The ruling design speed of 100 Kmph is adopted for the flyover and at grade roads.
41. *Carriageway Width.* Based on the traffic requirement as per projections, four lane configuration is proposed for the flyover and two lane width is proposed for the service roads. Foot cum drain of 2m is proposed.
42. *Camber.* Camber of 2.5% is proposed for carriageway of flyover as well as service roads.
43. *Super Elevation.* A maximum super elevation of 5.6% is adopted.

44. *Horizontal Geometry.* A design speed of 100 kmph is proposed for the flyover and at grade roads. The minimum horizontal curve radius proposed is 800m. The radius beyond which super elevation is not required is 1800m.
45. *Vertical Geometry.* Vertical alignment is designed based on the provision of IRC SP: 23. Design of vertical geometry has two components, viz. design of gradients, and design of vertical curves. Vertical curves were designed using a minimum “K-value” of 74 for crest and 42 for sag for speed 100 kmph. A gradient of 3% is proposed at the location of obligatory spans. Care was taken to limit the start and end gradients of the vertical curves within the ruling gradient.

## 2. *Road Signage and Markings*

46. Proper signage and markings are vital for safety and guidance of the drivers. Junction improvement drawings shall show warning and regulatory signs at appropriate locations. The signs are of reflector type to be noted easily at night. All road signs are in conformity with the provisions of IRC 67 – 2001- Code of Practice for Road Signs and IRC SP 31 – 1992 - New Traffic Signs.
47. Roadside lighting is provided for the flyover as well as service roads. Lamp poles are fixed at the edges of flyover. The road markings are in conformity with IRC 35 – 1997 Code of Practice for Road Markings with Paint and other IRC Standards.

## C. **Structural Design Standards**

48. The basic design standards adopted for the structural designs are as per the requirements laid down in the latest editions of IRC codes of practices & standard specifications and guidelines of Ministry of Road Transport & Highways. Additional technical references are used wherever the provisions of IRC/IS codes are found inadequate.
49. Following IRC/IS Codes are followed in the design

IRC:5 -1998      Standard Specifications & code of Practice for Road Bridges  
Section -I. General Features of Design

IRC:6-2000      Standard Specifications & code of Practice for Road Bridges,  
Section -II. Loads and Stresses

IRC:18-2000     Design Criteria for Pre-stressed Concrete Road Bridges (Post-  
Tensioned Concrete) (Third Revision)

IRC:21-2000     Standard Specifications & code of Practice for Road Bridges,  
Section -III. Cement concrete (Plain and reinforced )

IRC:22-1986     Standard Specifications and Code of Practice for Road Bridges,  
Section VI -Composite Construction (First Revision)

IRC:78-2000     Standard Specifications & code of Practice for Road Bridges, -  
Foundations & Substructure.

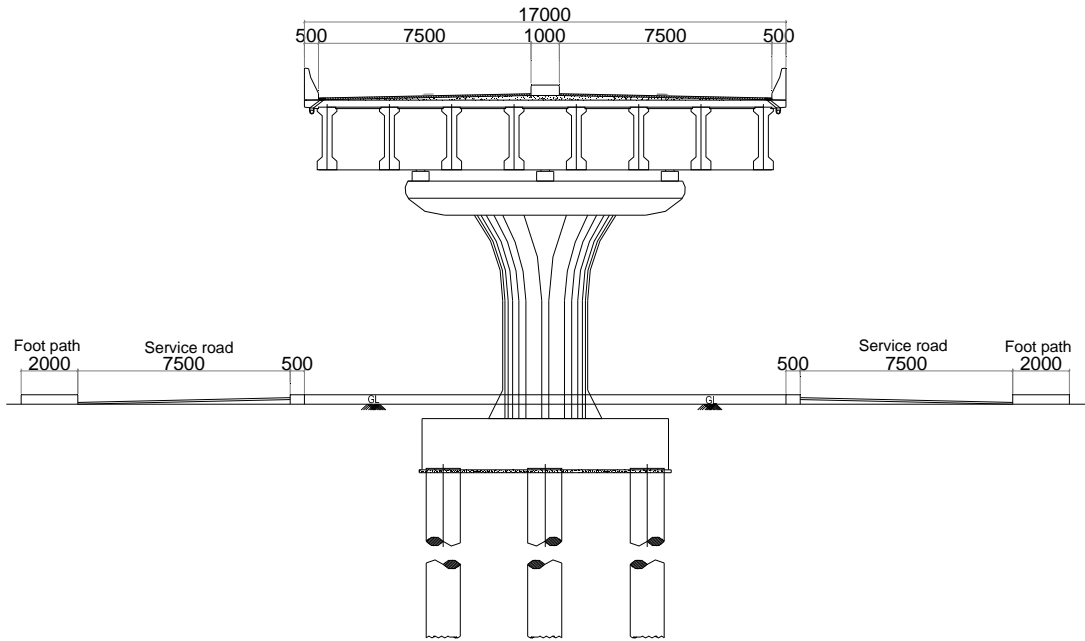
- IRC:69-2005 Guidelines and Specifications of Expansion joint  
 IRC:83(Part-III)-2002 Standard Specifications and codes of Practices for Road Bridges, Section IX –Bearing , Part II: POT Bearings  
 IS 2911-1979 Code of practice for design and construction of pile foundations

50. For the items not covered in the above specifications, provisions of following standards are followed in the given order of priority:
- Provisions of IS codes of Practices:
  - Relevant Provisions of BS codes of practices
  - Sound Engineering Practices, technical Literature/ Papers & Provisions of relevant codes of advanced and developing countries.

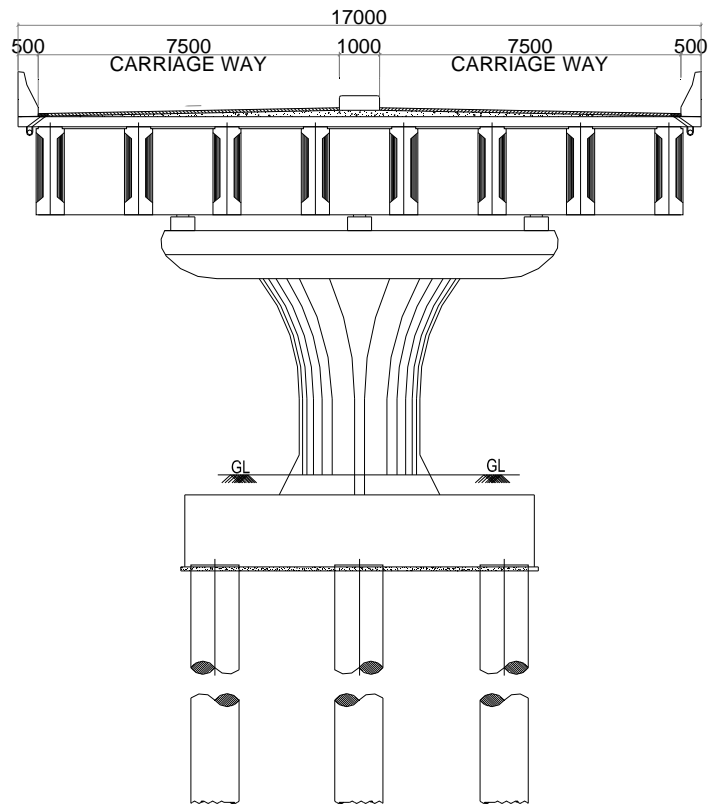
#### **D. Details of Improvement Proposals**

51. Taking into consideration the volume of traffic and pattern of movement, for decongesting the junction, it is proposed to provide a flyover along NH 24 which carries major share of traffic. This also segregates the through traffic from cross traffic. In view of high volume of traffic along this route, dual 2 lane carriageway separated by a central median is proposed for the flyover structure. Each 2 lane carriageway, intended for each direction of traffic, has a width of 7.5m with crash barriers of 0.5m width on extreme outer ends. The central median has a width of 1m. The existing alignment of NH 24 is followed for the flyover.
52. The flyover is on structure except for a small length on either ends. Earthen ramps with earth retaining structures on sides are proposed beyond the abutments on either side. Minimum vertical clearance of 5.5m is proposed from the at grade road top to the bottom of deck at the obligatory span locations at the junction.
53. The proposed flyover has total length of 640m with 16 numbers of spans of 40 m each, 5 numbers on Shahadra Border side and 9 numbers on Chandra Shekhar Chowk side apart from the two obligatory spans at the centre. The length of earthen ramp shall be 350 m and 200 m on Shahadra Border side and Chandra Shekhar Chowk side respectively. Thus the flyover and approaches including ramp portion shall have a total length of 1190 m. The obligatory spans at the junction shall have a length of 80 m (2 spans of 40m each).
54. At grade road of 7.5m width is proposed on either side of the flyover as service road for local and turning traffic. Footpath cum drains is also proposed at the outer edges of these roads on both sides. The typical cross sections are shown below.

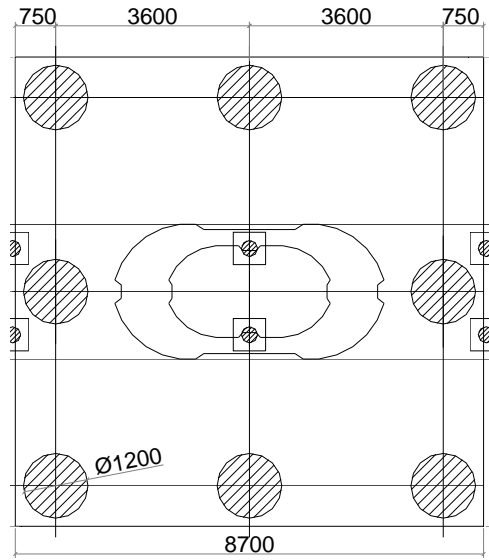
**Figure 4-1:** Typical cross section of flyover



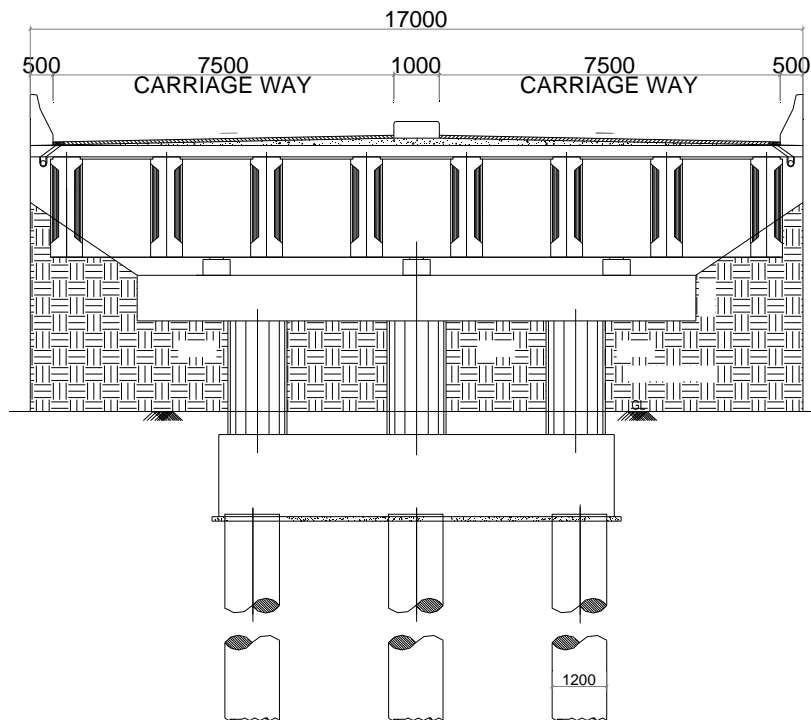
**Figure 4-2:** Typical cross section at pier

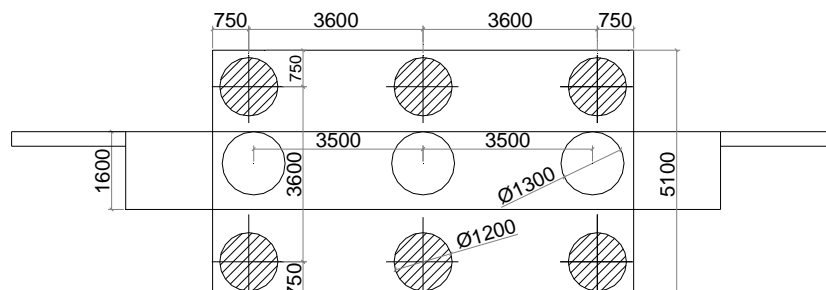


**Figure 4-3: Plan at Pier**



**Figure 4-4: Typical Cross-section at Abutment**



**Figure 4-5: Plan at Abutment****E. Improvements to Existing Traffic Regulations**

55. The proposal of flyover requires improvement and reorganization of the traffic arrangement existing at the junction. The traffic shall be channalized ensuring proper turning radius. To avoid conflicts between right turning traffic from Madan Mohan Malavya Marg and Loni Road, signal control is proposed at the junction. Traffic regulation arrangements like islands, signals etc. now present is reorganized to facilitate smooth turning of vehicles.

**F. Right of Way**

56. The available ROW along NH 24 in the project site location varies from 36m to 39m as per revenue records. The Right of Way requirement for the proposed improvement is worked out to be about 40m.

**G. Salient Features of Proposed Flyover**

57. Various structural arrangement options were studied for the proposed flyover based on:
- Functional requirement
  - Characteristics of subsoil
  - Facilities to be provided at grade
  - Ease in construction
  - Economy etc.
58. Accordingly, the structural system was planned taking into account suitability of the same at the proposed location, constructability, level of impact on traffic movement during construction etc. Based on subsoil report and preliminary design it is estimated that a span

length of 35 to 40m will be economical. Considering the distance of coverage required for obligatory spans, a span length of 40m is adopted there and the same span length is followed for the entire length of the flyover. Thus, a total of 16 spans of 40 m length are proposed for the elevated structure. The remaining portion is on earthen ramps on either side.

### 1. *Superstructure*

59. As longer spans are proposed, pre-stressed concrete superstructure is adopted. The four lane deck shall consists of 8 numbers of pre-cast post tensioned I- girders with in-situ RCC slab. The girders are spaced at 2.2 m. Cross diaphragms are proposed at support locations. The superstructure is supported by POT-PTFE bearings.

### 2. *Substructure*

60. The substructure proposed is RCC hammer headed piers with shaft flaring towards top portion and straight portion below is proposed. Single pier arrangement is proposed for the four line superstructure. Pier cap is cantilevered out to accommodate the girders. Height of pier is based on the clearance requirement. Where vehicles are to cross below, the minimum vertical clearance requisite of 5.5 m is ensured. At other support locations, the pier height varies in line with the road profile.

### 3. *Foundation*

61. The foundation type depends on the subsoil nature and condition at the location. Four bore holes were taken at 100m interval to get a fair idea of the subsoil composition and to decide on the suitable founding levels. Various tests were conducted at the field and laboratory to assess the subsoil composition and nature. Soil samples were collected from different levels of the bore holes and tested in the laboratory to obtain the soil parameters and properties. Based on the test results, it is found that deep foundation is required at the location. As such pile foundation is proposed to be taken to an average depth of 25 m from the ground level. The piles shall be of 1.2m diameter.

## H. **At Grade Roads**

62. At grade roads with 7.5 m wide carriageway and 2.0 m wide footpath cum drains at the outer ends are proposed on either side of the flyover to cater for the turning traffic from cross roads. These roads are to be formed widening the existing pavement of NH 24; the existing road level is kept for the widened portion also. The sub grade soil investigation shows good top soil with 8% CBR where the pavement layers can be laid directly.
63. The width of footpath has been derived from the volume of pedestrian traffic at the location. The drain shall have a width of 1.5m and is placed at the extreme end of the road.

64. The pavement design is carried out in accordance with the guidelines of IRC 37 – 2002. The results of the traffic survey and the projected traffic volume worked out in **Chapter 3** are made use of in the pavement design. The design traffic is considered in terms of the cumulative number of standard axles to be carried by the pavement during the design life of the road and is derived from the initial volume of commercial vehicles per day, growth rate, design life in years and the vehicle damage factor (number of standard axle per commercial vehicle) to convert commercial vehicles to standard axles.
65. 20 MSA and 15 MSA are adopted for the pavement design of flyover and at grade road respectively to arrive at the pavement layer composition.

#### **I. Utility Relocation Plan**

66. Proposal for shifting the utilities which fall within the project alignment have been prepared. The details of utilities falling along the project alignment are mentioned in **Chapter 2**. There are 33 lampposts present along the project alignment, which have been removed, and lighting arrangement have been proposed in the flyover portion for both flyover and at grade roads. The cost for new lighting has been included in the cost estimates. There are 36 trees falling along the proposed flyover alignment, which have to be felled during the construction phase. As a compensatory measure, it is proposed to plant thrice the number of trees to be felled with site specific indigenous species and also to transplant the small trees wherever possible. For all the remaining utilities, shifting proposal is given in a separate drawing.

## 5. DESIGN REPORT

### A. General

67. Detailed design of the proposed flyover has been carried out based on the data collected during various surveys like topographical survey, geotechnical survey and also as specified in the traffic study findings. Apart from different survey outcomes, the urban environment of the area also played a major role in deciding the span length, type of superstructure, shape of substructure etc. Latest versions of relevant standard codes of practices published by Indian Roads Congress (IRC) and MoSRTTH standard specifications have generally been followed in finalizing the design concept and in the design of various structural components.

### B. Structural Arrangement of Flyover

68. The 4 lane elevated structure is proposed to have a total width of 17.0 m consisting of 7.5 m carriageway for each direction of traffic, 0.5 m wide crash barriers on either outer ends and 1.0 m wide median at the centre. The alignment of the existing road is followed for the flyover structure also. Vertical clearance varying from 5.8m to 6.8m is provided for the obligatory spans at the junction proper. The obligatory span consists of two numbers of 40 m each. Post-tensioned I-girders with cast in situ deck slab is proposed as superstructure. The girders shall be spaced at 2.2 m apart with cross diaphragms at supports. The cross diaphragms shall be resting on POT-PTFE bearings. RCC hammer headed piers with shaft flaring towards top portion and straight portion below is proposed. Pier cap shall be cantilevered out to accommodate the girders. RCC trestle abutments are proposed. Reinforced earth walls are proposed to retain earth behind the abutment and on sides of ramp portion.
69. The foundation system consists of bored cast in situ pile groups of 1.2m diameter with average founding levels about 25 m below the existing ground level. Six numbers of piles are proposed for the abutments and 8 numbers are proposed for piers.

### C. At Grade Roads

70. The at- grade roads on either side of the flyover shall be of two lane configuration with carriageway width of 7.5 m. Footpaths and drains having width 2m are provided on the outer edges. Typical arrangement of flyover and at grade road is given in the previous section.

## D. Design Methodology

### 1. Geometric Design Standards

71. The geometric designs of the improvement proposal have been carried out following relevant standards of IRC. The adopted design standards from the code are given in **Table 5-1**.

**Table 5-1:** Geometric Design Standards

S. No	Description	Standard	
1	Design speed (Kmph)	100 Kmph	
2	Lane width	3.5 m	
4	Service Road	7.5m	
5	Footpath cum Drain	2m	
6	Cross-slopes		
	Structure portion	Carriageway	2.5 %
	Road portion	Carriageway	2.5%
7	Maximum super elevation	Plain terrain	5.6%
8	Minimum horizontal curve radius	800m	
9	Radii beyond which super elevation not required	1800m	
10	Gradient	Max. gradient	3%
11	Vertical curve 'K' values	Crest	Sag
	Crest curve/Sag curve	74	42
12	Vertical clearance	5.8m to 6.8m	

### 2. Proposed Geometry

72. *Horizontal Geometry.* A design speed of 100 kmph is adopted for the flyover proposed at Mohan Nagar Chowk. The detailed Horizontal Alignment Report is given below in **Table 5-2**.
73. *Vertical Geometry.* Design of vertical geometry has two components, viz. design of gradients, and design of vertical curves. Vertical curves were designed using a minimum "K-value" of 74 for crest and 42 for sag for speed 100 kmph. Care was taken to limit the start and end gradients of the vertical curves within the ruling gradient. Details of proposed vertical curves are given in **Table 5-3**.

**Table 5-2: Summary of Horizontal Alignment Report**

S No	Curve No	Side	Ch Start	Ch End	Easting	Northing	Deflection Angle (Deg Min Sec)	Radius (m)	Length of Arc (m)	Tangent Length (m)	Apex Distance (m)	Preceding Transition Length (m)	Following Transition Length (m)	Speed (kph)
1	1/1 (L)	Left	0+150.648	0+178.461	731849.108	3174648.163	00°19'07.388''	5000	27.813	13.907	0.019	0	0	100
2	1/2 (R)	Right	0+241.342	0+304.661	731957.219	3174656.694	00°27'12.559''	8000	63.319	31.66	0.063	0	0	100
3	1/3 (L)	Left	0+497.973	0+548.576	732206.865	3174674.406	00°43'29.433''	4000	50.604	25.302	0.08	0	0	100
4	1/4 (R)	Right	0+548.576	0+622.362	732206.865	3174679.593	00°50'43.863''	5000	73.785	36.893	0.136	0	0	100
5	1/5 (L)	Left	0+735.318	0+760.580	732430.94	3174690.751	00°10'51.335''	8000	25.262	12.631	0.01	0	0	100
6	2/1 (R)	Right	0+878.041	1+178.041	732710.513	3174710.882	07°18'51.677''	2350	300	150.204	4.795	0	0	100
7	2/2 (R)	Right	1+439.708	1+612.597	733208.391	3174683.084	12°22'56.023''	800	172.889	86.782	4.693	0	0	100

**Table 5-3: Summary of Vertical Alignment Report**

SI No.	Element Start Chainage (km)	Element End Chainage (km)	Curve Start Gradient (%)	Curve End Gradient (%)	Straight Gradient (%)	Algebraic Difference (%)	Length of Curve/ Straight	K value	Curve Type	Design Speed (kmph)
<b>Flyover</b>										
1	0+000	0+290	0	0	1.5	0	289.691	0	-	100
2	0+290	0+370	1.5	0.3	-	1.2	80	-66.66	hog	100
3	0+370	0+620	0	0	0.3	0	247.209	0	-	100
4	0+620	0+700	0.3	3	-	-2.7	80	29.62	sag	100
5	0+700	0+810	0	0	3	0	114.1	0	-	100
6	0+810	1+290	3	-3	-	6	480	-80	hog	100
7	1+290	1+630	0	0	-3	0	339.106	0	-	100
8	1+630	1+710	-3	-0.6	-	-2.4	80	33.33	sag	100
9	1+710	1+910	0	0	-0.6	0	199.528	0	-	100
10	1+910	1+970	-0.6	0.3	-	-0.9	60	66.66	sag	100
11	1+970	2+170	0	0	0.3	0	168.93	0	-	100
<b>At Grade Road</b>										
1	0+000	0+095	0	0	1.069	0	95.745	0	-	100
2	0+095	0+155	1.069	2.000	-	0.931	60	64.42	sag	100
3	0+155	0+250	0	0	2.000	0	92.168	0	-	100
4	0+250	0+400	2.000	-0.3	-	2.300	150	-65.21	hog	100
5	0+400	0+490	0	0	-0.3	0	92.643	0	-	100
6	0+490	0+590	-0.3	0.6	-	-0.9	100	111.11	sag	100
7	0+590	0+860	0	0	0.6	0	267.44	0	-	100
8	0+860	0+960	0.6	-1	-	1.6	100	-62.5	hog	100
9	0+960	1+710	0	0	-1	0	749.308	0	-	100
10	1+710	2+010	-1	0.3	-	-1.3	300	230.76	sag	100
11	2+010	2+170	0	0	0.3	0	168.93	0	-	100

## E. Pavement Design

### 1. Design of Flexible Pavement for New Pavement as per IRC: 37-2001

74. *Traffic Forecast and Design Traffic.* Traffic data obtained from traffic survey and analysis have been used for design of pavements. Out of the various types of vehicles encountered during classified traffic volume counts LCV, Bus, 2-Axle and multi axle trucks have been considered as commercial vehicles in pavement design. **Table 5-4** gives the summary of ADT obtained from the traffic survey for the proposed approaches to grade separators.

**Table 5-4:** Summary of Commercial Vehicles Average Daily Traffic (ADT) in 2008

S. No	Road Section	No. Of Commercial Vehicles per day				
		LCV	BUS	2 Axle	MAV	Total
1	Approach roads to flyover structure	203	701	494	170	1568
2	Adjacent roads of flyover structure	68	342	584	216	1210

75. *Design Traffic in CMSA (Cumulative Million Standard Axles).* The design traffic is considered in terms of cumulative number of standard axles to be carried during the design life of the road. Its computations involves estimates of the initial volume of commercial vehicles per day, lateral distribution of traffic, the growth rate, the design life in years and the vehicle damage factor to convert commercial vehicles to standard axles.
76. Out of the various types of vehicles encountered during traffic counts and axle load surveys, Light Commercial Vehicles (LCV's), Buses, 2-Axle Trucks, 3 Axle Trucks and Multi Axle Vehicles (MAV's) have been considered as commercial vehicles.
77. The following equation is used to compute the design traffic  $N_s$ , in terms of the cumulative number of standard axles.

$$N_s = \frac{365 \times [(1+r)^n - 1] \times A \times D \times F}{r}$$

Where,

$r$  = Annual growth rate of commercial vehicle

$n$  = Design life in years

$A$  = Initial Traffic in the year of completion of construction in terms of the number of commercial vehicles per day- The traffic in the year of completion is estimated using the following formula:

$$A = P (1+r)^x$$

Where,  $P$  = Number of commercial vehicles as per last count

$X$  = Number of years between the last count and the year of completion of construction

Assuming the construction period as 2 years for construction of flyover, including time taken for award of work the estimated traffic, 'A' in the year of completion of construction

is given in the **Table 5-5**.

**Table 5-5:** Estimated traffic at the end of construction period

S. No	Road section	P	A
1	Approach roads to flyover structure	1568	1694
2	Adjacent roads of flyover structure	1210	1334

D = Lane Distribution Factor- Since the present study is for the construction of dual two lane, D is adopted as 75% of the total number of commercial vehicles in each direction for dual two lane.

F = Vehicle Damage Factor (VDF) - defined as equivalent number of standard axles per commercial vehicle. It is a multiplier to convert the number of commercial vehicles of different axle loads and axle configuration to the number of standard axle load repetitions.

If Initial traffic volume in terms of number of commercial vehicles per day varies from 0 – 150, 150 – 1500 & more than 1500 commercial vehicles per day, national average vehicle damage factor as per IRC: 37-2001 is taken as 1.5, 3.5 & 4.5 respectively.

Ns = Cumulative no. of Million Standard Axles (CMSA)- The design traffic in terms of cumulative number of million standard axle load repetitions obtained as per IRC 37 for a design period of 15 years are given in the **Table 5-6**.

**Table 5-6:** Cumulative number of Million Standard Axles (CMSA)

S. No	Road section	Cumulative number of million standard axles				
		LCV	BUS	2 Axle	MAV	Total
1	Approach roads to flyover structure	1.75	6.04	6.25	2.15	16.19
2	Adjacent roads of flyover structure	0.25	2.95	7.39	2.73	13.32

78. Thus, from the above table the design traffic in terms of cumulative number of million standard axles (CMSA) is rounded up & taken as 20 CMSA and 15 CMSA for Approach flyover and Adjacent roads.

## 2. Existing Sub grade and Design CBR

79. *Borrow Area:* The samples collected from near by borrow area and shows good quality soil which can be used for the sub grade. The 4 days soaked CBR value of the sample tested found to be 8% and the same is proposed to be used for sub grade.

80. *Design CBR:* Keeping in view the soil characteristic as stated above, the pavement for the project road has been designed adopting CBR value of sub grade as 8%.

### 3. Pavement Design

81. Considering the sub grade soil CBR of 8% and design traffic as given in **Table 5-6**, the new flexible pavement thicknesses obtained for a design life period of 15 years as per IRC 37 works out as under in **Table 5-7**.

**Table 5-7:** Proposed Design of Flexible Pavement for a Design Life Period of 15 Years

Road section	Pavement Design Thickness (mm) for Design Subgrade CBR 8%					
	Design Traffic	GSB	WMM	DBM	BC	Total
Approach roads to flyover structure	20	200	250	85	40	575
Adjacent roads of flyover structure	15	200	250	75	40	565

**Note:** Above the existing road surface adjacent to flyover, flexible overlay of 40mm BC +75mm DBM is proposed.

**Figure 5-1:** Typical Cross Section showing layers of Pavement Composition



### 4. Structural Design Standards

82. The design methodology is mainly devised from the method of construction proposed to be adopted. Considering the intensity of daily traffic taking this route which warrants speedy completion of the whole work, pre- cast construction method is adopted. The post tensioned girders shall be casted in the yard and transported to the site and thus ensuring minimum time for construction. Designs have been done for transfer and service stages.
83. *Loading Standards.* The structural system is designed for loadings as per IRC 6: 2000. The basic loadings considered are:
- Dead load constituting of self weight of structural members
  - Superimposed dead load constituting of weight of wearing coat, crash barrier and median
  - Live load constituting of loads due to 4 lanes of IRC Class A vehicles or 2 lanes of IRC class 70R vehicles whichever produces the worst effect
  - Wind load as applicable to the site based on the height

- Seismic load as per provisions in IRC code relevant for Seismic zone IV

84. *Condition of Exposure and Grade of Concrete.* Due to presence of chlorides in the subsurface water, severe condition of exposure is considered in the design. The minimum grade of concrete and clear cover to reinforcement proposed is based on the severe exposure condition. Design mix is proposed for all grades of concrete.

## F. Design of Superstructure

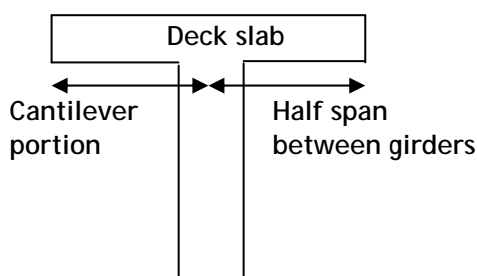
### 1. Post tensioned Girders

85. *Grillage Analysis of Girder:* A grillage model of the superstructure arrangement is prepared. The longitudinal members of the grillage are formed by the main girders. The cross girders and deck slab form the transverse members of the grillage.

86. *Section Properties.* The section properties of various members of the grillage are calculated. Area of cross section, Moment of inertia, location of centre of gravity etc is calculated. A small value of torsional moment of inertia is used in the analysis to get worse effects on the members. The members in the grillage are idealized in to the following:

- (i) Virtual members: This forms the extreme edges of the superstructures. These edge members are given negligible properties as to include them in the analysis to complete the form but not to include its effect.
- (ii) End girder members: This represents the end girders on either side. The property of this member is calculated by considering a T- section. The cantilever portion of deck slab on one side and deck slab length equal to half the spacing between the girders on the other side together form the flange of the T-section. At the locations of the curves, the cantilever length of the deck slab is taken as the average cantilever length at two nodes of each member. The web portion is constituted by the I-girder.

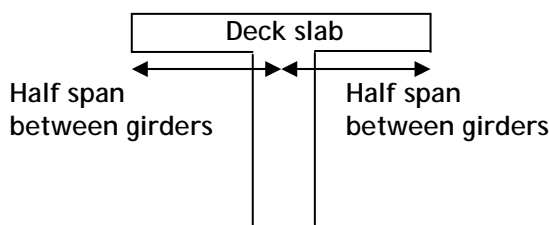
**Figure 5-2:** Typical End Girder Section



- (iii) Mid girder members: This represents the intermediate girder. The property of this

member is calculated by considering a T- section. The deck slab length equal to half the spacing between the girders on the either side forms the flange of the T-section. The web portion is constituted by the I-girder.

**Figure 5-3: Typical Mid Girder Section**



**TYPICAL MID GIRDER SECTION**

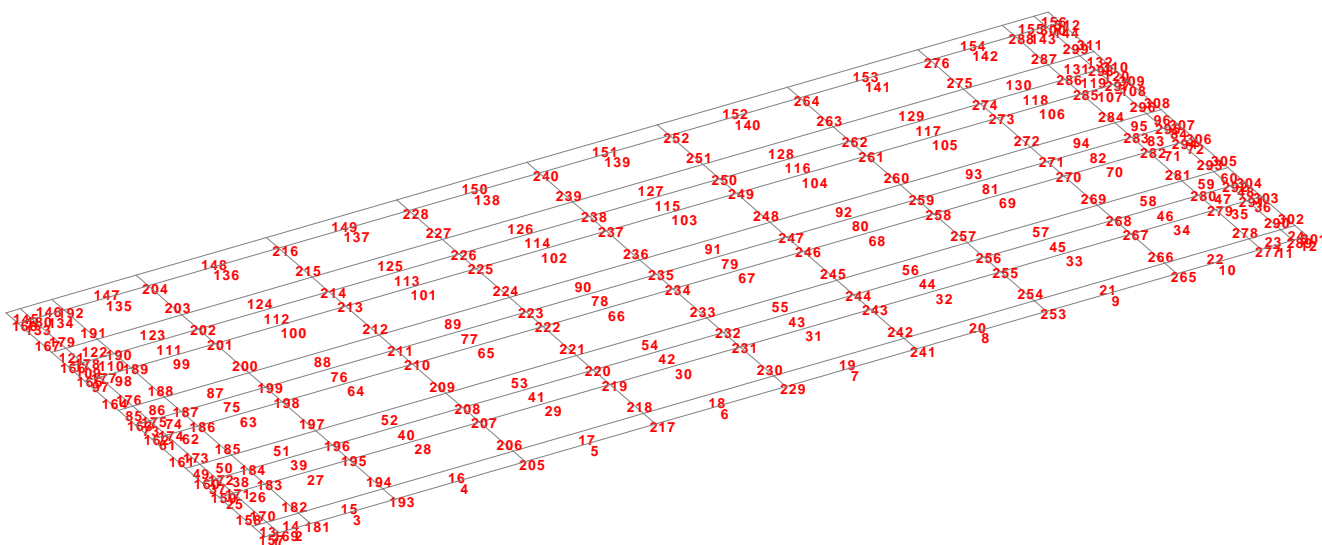
- (iv) **End Cross Girder Members:** This represents cross girders provided at the pier/abutment locations. The property of this member is calculated by considering a T- section. Effective width is considered based on the longitudinal girder spacing.
- (v) **Intermediate Cross Diaphragm Member:** This represents diaphragms provided at the mid span of girder. The property of this member is calculated by considering a T- section. Effective width is considered based on the longitudinal girder spacing.
- (vi) **Other Transverse Members:** The span of the grillage is divided into equal number of convenient sections.(imaginary) The property of these members are calculated based on its position and the spacing of this imaginary sections. Accordingly following different entities are considered
  - **Slab Adjacent to End Cross Girder:** The property of this member is calculated considering it as a rectangular section the depth being the depth of the deck slab and the width being the width from slab edge to the mid of the spacing between imaginary sections. The effective width of end cross girder considered in the design is deducted from the width calculated for this member.
  - **Slab Adjacent to Intermediate Cross Girder:** This is considered only if the intermediate cross girder is provided. The property of this member is calculated considering it as a rectangular section the depth being the depth of the deck slab and the width being the spacing between imaginary sections. The effective width of intermediate cross girder considered in the design is deducted from the width calculated for this member.
  - **Middle Slab:** The property of this member is calculated considering it as a rectangular section the depth being the depth of the deck slab and the width being the spacing between imaginary sections.
  - **Intermediate Cantilever Slab:** The property of this member is calculated considering it as a rectangular section the depth being the depth of the cantilever portion of deck slab and the width being the spacing between imaginary sections.

- **End Cantilever Slab:** This forms the corner members of the grillage. The property of this member is calculated considering it as a rectangular section the depth being the depth of the cantilever portion of deck slab and the width being half the spacing between imaginary sections.

87. *Loading.*

- (i) **Dead Load:** The dead weight of each component is calculated from the area of cross section calculated for each member. The dead weight of each member is applied as UDL. Density of concrete is taken as 25 kN/m<sup>3</sup>.
- (ii) **Superimposed dead load:** Load due to crash barrier, median, wearing coat and pre-cast panels is included in this. The loads are applied locally on the members on to which the loads are transferred (separate analysis is carried out to distribute the footpath load on different girders). The utility load is considered separately. Density of concrete is taken as 24 kN/m<sup>3</sup>. Density of wearing coat is considered as 22 kN/m<sup>3</sup>. Utility load is taken as 2 kN/m.
- (iii) **Live Load:** Moving load analysis is carried out for both Class A and Class 70R load cases (and their combination where required). Different positions of wheels in the transverse directions are considered as to induce maximum effect. Two typical cases were considered
  - The wheel was arranged at minimum distance (as specified in IRC 6-2000) from the crash barrier edge.
  - The worst effect due the live load case was combined with the Dead load and Superimposed dead load as to arrive at the design values of moments and shear.

Figure 5-4: Grillage model for superstructure analysis



88. *Design of PSC Girder.* The design of PSC girder is carried out based on accepted theories. Following losses were considered in the design

- (i) Initial losses
    - Elastic shortening
    - Relaxation of steel (one part –IRC 18-2000 – clause 11.4)
  - (ii) Time dependent losses
    - Shrinkage of concrete
    - Relaxation loss (remaining part) As per IRC 18:2000, (Cl 11.4), three times 1000hr value due to relaxation is considered in service condition.
    - Creep losses
    - Long term time dependant losses: 20 % of total loss due to shrinkage, creep and relaxation losses
  - (iii) Other effects
    - Differential shrinkage: The effect of differential shrinkage is calculated considering a differential shrinkage strain of 0.00010 and reduction factor of 0.43.
    - Temperature effects: The effect of rise/fall of temperature is considered as explained in IRC 6-2000. As per code specification (IRC 18-2000) 50% of live load is considered in arriving at the stresses while considering temperature effects.
89. The design has been carried for the worst girder. The design at critical sections like support, L/8 etc are also checked to arrive at the number of strands to be de-bonded at respective locations in case of pre-tensioned girders and to arrive at the cable profile in case of Post tensioned girders.
90. The design is checked for ultimate strength (moment and shear) in accordance with IRC - 18-2000 Clause 12.
91. *Transverse Analysis for Deck Slab Design.* The transverse analysis of the deck slab is carried out using software. The slab is treated as a continuous member supported at the girder locations. The self weight of deck slab is applied as uniformly distributed load on the slab. The load due to crash barrier, wearing coat and median is considered as the superimposed dead load. This is also applied as UDL, at respective locations. For the application of live load, various possible critical arrangements of wheel loads are considered. For different arrangements, the effective dispersion of each wheel and the net distributed load is calculated. This load is applied as UDL over the worked out dispersed area. The following cases of live loads were studied:
- (i) The maximum wheel load at minimum distance from the crash barrier edge
  - (ii) Maximum wheel load in the central span
  - (iii) Maximum wheel loads equidistant from one of the girders
  - (iv) One span loaded and the adjacent span with no load
92. All the above cases are checked for Class A load and Class 70R load. An impact percentage of 10 is adopted for the live loads. Combination of different live load cases with the Dead load and Superimposed dead load is carried out. The following design

moments are calculated:

- (i) Maximum hogging moment at the extreme support (cantilever location)
  - (ii) Maximum hogging moment at the intermediate support
  - (iii) Maximum sagging moment at mid span between supports
93. The design is carried for the critical moment. The design is also checked for composite action as per IRC 22-1984.
94. *End Cross Girders*: End cross girder is analyzed as a continuous beam with loads from dead load of longitudinal girder, deck slab, superimposed dead load and live load as pointed loads at girder ends. The self weight of the Cross girder is considered as UDL.
95. *Loadings*.
- (i) Dead Load: The self weight of the superstructure is considered as the dead load. For RCC works the density of concrete is taken as 24kN/m<sup>3</sup>. For PCC and wearing course works, the density is taken as 22kN/m<sup>3</sup>.
  - (ii) Live Load: The design is done for two lanes of live loading. Worst case of the following combinations is considered for girder design:
    - Two lanes of IRC 70R - near median on either carriageway
    - Two lanes of IRC 70R – one near crash barrier and other one near median on other side
    - Four lanes of IRC Class A – near crash barrier
    - Four lanes of IRC Class A – near median
    - Two lanes of IRC Class A – near crash barrier
    - Two lanes of IRC Class A – near median
    - Two lanes of IRC Class A near crash barrier on one side and one 70R on the other side
    - Two lanes of IRC Class A near median on one side and one 70R on the other side
  - (iii) Impact: Provision for impact or dynamic action due to live load is accounted as per Clause 211.1 of IRC 6: 2000. The live load is incremented by the impact percentage. For Class A loading the impact percentage is calculated as per the standard formula in Clause 211.2 or Fig 5 of IRC 6:2000. For Class 70R loading impact is considered as per clause 211.3.
96. Analysis of the superstructure is carried out on a FEM model. A grid model representing the deck slab and supporting arrangement with truss members is developed. Analysis model for transverse analysis of deck slab is also done in FEM software. Design moments and shear forces are taken from the output of the software.

## G. Design of Substructure and Foundation

97. The design of substructure and foundation of the flyover is carried out based on IRC 6-2000 and IRC 78-2000. The latest amendments of IRC 6:2000, IRC 78:2000 etc are adopted in the design. RCC hammer headed piers with flaring on the top portion and straight portion below is proposed. Pier cap is provided over the flaring. Abutments are designed similar to piers with no earth pressure forces. The effects of load from one side span alone are considered in the abutment design.
98. Primary Loads considered:
- (i) Dead Load: Vertical load due to dead load of the superstructure on the abutment and the self weight of abutment is considered. The density of concrete is taken as briefed above.
  - (ii) Superimposed Dead Load: Vertical load from superstructure due to superimposed dead load is considered under this loading.
  - (iii) Live Load: Effects due to following cases are studied and worst case of these is considered in the design.
    - Single lane IRC 70R placed at extreme end
    - Two lanes of IRC 70R
    - Single lane of IRC class A
    - Four lanes of IRC class A
  - (iv) Braking Load: 20% of the first train load plus ten percent of the load of the succeeding trains or part thereof is considered for two lanes of loading in accordance with Cl. 214.2.a of IRC 6: 2000.
  - (v) Longitudinal force due to bearing friction: The longitudinal force on fixed and free bearing is calculated as per Clause 214.5.1.1 in IRC 6 2000.
  - (vi) Seismic Load (Longitudinal and Transverse): The seismic forces are calculated using Elastic Response Spectrum method as per latest amendment of IRC.6.2000 dated 28.05.2009. The seismic force is calculated considering the respective Zone factor (0.24), Importance factor (1.2), Response reduction factor (2.5 for abutments and 3.3 for piers), Fundamental period of vibration, Soil type (Type II soil) etc. The seismic forces in longitudinal and transverse direction are found out separately. The design seismic force resultant in longitudinal and transverse direction is adopted as prescribed in the latest amendment. Effects of Zone IV are considered in the design. The live load effect is not considered in the longitudinal direction where as 20% of live load is taken in transverse direction.
  - (vii) Wind Load: The wind force is calculated based on the wind pressure, in accordance with the latest amendment of IRC.6.2000 dated 31.1.2008. Wind force depends upon several factors like hourly mean wind pressure, solid area, gust factor and drag co-efficient. The longitudinal (25% of the transverse moment) and transverse wind moments are found as given in the code. Separate cases for upward and downward wind load are carried out as per codal guidelines. The effects of wind load are supposed considered in the design of substructure. Wind load is considered at the centroid of appropriate superstructure areas.

- (viii) Collision Load: The collision load is calculated as per clause 225 of IRC 6:2000. With these primary loads, the following load combinations are formed:

Case 1: Both Spans On.

- Axial load = Dead load of substructure + DL and SIDL of superstructure + live load.
- Longitudinal Moment = Moment due to braking, temperature and shrinkage  
Moment due to longitudinal eccentricity of live load + Moment due to DL + SIDL of superstructure
- Transverse Moment = Moment due to transverse eccentricity of live load,  
Dead load, Superimposed dead load

Case 2: One Span dislodged condition with Class A One lane.

- Axial load = Dead load of substructure + DL and SIDL of superstructure (from one side) + live load.
- Longitudinal Moment = Moment due to braking, temperature and shrinkage  
Moment due to longitudinal eccentricity of live load + Moment due to DL + SIDL of superstructure
- Transverse Moment = Moment due to transverse eccentricity of live load,  
Dead load, Superimposed dead load

Case 3: Both Spans on under seismic in longitudinal direction.

- Axial load = Dead load of substructure + DL and SIDL of superstructure + live load (50%).
- Longitudinal Moment = Moment due to braking(50%), temperature and shrinkage + Moment due to longitudinal eccentricity of live load (50%) + Moment due to seismic force
- Transverse Moment = Moment due to transverse eccentricity of dead load, superimposed dead load, live load(50%)

Case 4: Both Spans on under seismic in transverse direction.

- Axial load = Dead load of substructure + DL + SIDL of superstructure + live load (50%).
- Longitudinal Moment = Moment due to braking (50%), temperature and shrinkage + Moment due to longitudinal eccentricity of live load (50%)
- Transverse Moment = Moment due to transverse eccentricity of live load(50%) + Superimposed dead load+ Moment due to seismic force

Case 5: One Span dislodged under seismic in longitudinal direction.

- Axial load = Dead load of substructure + DL + SIDL of superstructure (from one side) + live load (50%).
- Longitudinal Moment = Moment due to braking(50%), temperature and shrinkage + Moment due to longitudinal eccentricity of live load(50%) + Moment due to DL + SIDL of superstructure + Moment due to seismic force

- Transverse Moment = Moment due to transverse eccentricity of live load (50%), Dead load, Superimposed dead load

Case 6: One Span dislodged under seismic in transverse direction.

- Axial load = Dead load of substructure + DL + SIDL of superstructure (from one side) + live load (50%).
- Longitudinal Moment = Moment due to braking(50%), temperature and shrinkage + Moment due to longitudinal eccentricity of live load(50%)+ Moment due to DL + SIDL of superstructure
- Transverse Moment = Moment due to transverse eccentricity of live load (50%), Dead load, Superimposed dead load+ Moment due to centrifugal force (50%) + Moment due to seismic force

Case 7a: Service condition with Wind in Transverse direction (Wind load acting upward).

- Axial load = Dead load of substructure + DL + SIDL of superstructure + live load + Wind load acting upwards.
- Longitudinal Moment =Moment due to braking, temperature and shrinkage + Moment due to longitudinal eccentricity of dead load, superimposed dead load and live load + Moment due to DL + SIDL of superstructure + Moment due to longitudinal wind force
- Transverse Moment =Moment due to transverse eccentricity of live load + Superimposed dead load+ Moment due to transverse wind force

Case 7b: Service condition with Wind in Transverse direction (Wind load acting downward).

- Axial load = Dead load of substructure + DL + SIDL of superstructure + live load - Wind load acting downwards.
- Longitudinal Moment =Moment due to braking, temperature and shrinkage + Moment due to longitudinal eccentricity of dead load, superimposed dead load and live load + Moment due to DL + SIDL of superstructure + Moment due to longitudinal wind force
- Transverse Moment =Moment due to transverse eccentricity of live load + Superimposed dead load + Moment due to transverse wind force

Case 8: Effect of collision in longitudinal direction

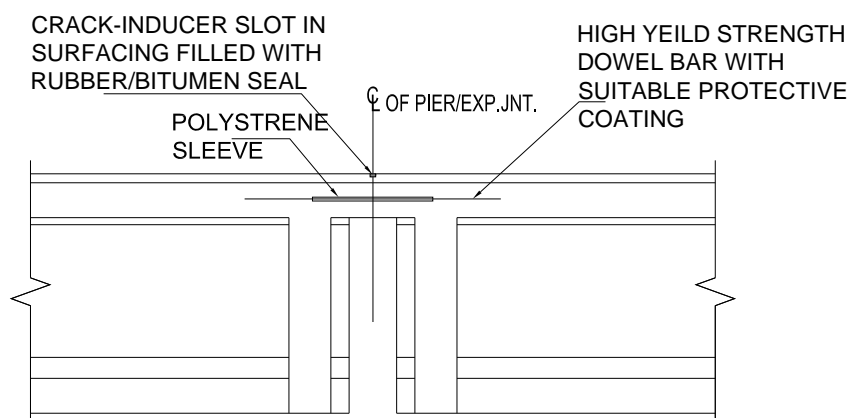
- Axial load = Dead load of substructure + DL + SIDL of superstructure
- Longitudinal Moment =Moment due to collision load in longitudinal direction
- Transverse Moment = Moment due to collision load in transverse direction

Case 9: Effect of collision in transverse direction

- Axial load = Dead load of substructure + DL + SIDL of superstructure

- Longitudinal Moment = Moment due to collision load in longitudinal direction
  - Transverse Moment = Moment due to collision load in transverse direction
99. The design of the substructure is carried out based on the theory of sections subjected to axial force and biaxial bending. Routines available in standard references are adopted for finding out the stresses in steel and concrete at critical sections.
100. *Foundation.* Depending upon the sub soil investigations, Pile foundations are proposed at abutment and pier locations. Foundation depth is fixed at about 25m below the ground level.
101. *Design of Pile Foundation.* From the design loads obtained for piers and abutments, the vertical and horizontal load distribution on each pile of the pile group is evaluated using standards methods. All the load cases considered for pier design are considered for pile design also. The loads and moments acting on the pile cap are transferred to the piles by the combined stress equation. The lateral load coming on each pile for all load cases is calculated and corresponding longitudinal and transverse moments are found depending on the depth of fixity of piles. The horizontal and vertical loads on the pile are compared with the respective capacities of the pile. The design is carried out using Standard Charts.
102. *Miscellaneous Design.*
- (i) Bearings. POT-PTFE bearings are proposed considering bearing arrangement and the envisaged loading. Details of loading and movements for various cases are brought out in the bearing drawings.
  - (ii) Expansion Joint. Strip seal expansion joints of required movement capacities are proposed. At support/pier locations, continuity at deck slab level is achieved adopting the arrangement shown below.

**Figure 5-5: Details of Expansion Joint**



103. Detailed analysis and design of various elements of fly over summarised in this section are presented in **Volume V-A2: Detailed Design Report**. Detailed drawings are given in **Volume V-A3: Detailed Drawings**

## 6. BILL OF QUANTITIES COST ESTIMATES

### A. Bill of Quantities

104. Total item wise quantities for flyover are calculated as per the detailed drawings. Separate heads for all different items of work is included in the BOQ. The major work items considered are:

- (i) Earth work
  - Excavation
  - Approach sub grade
  - Landscaping
- (ii) Pavement works
  - Granular sub base
  - Wet mix macadam
  - Bituminous works
  - Wearing course over Deck slab
- (iii) Concrete
  - PCC leveling Course
- (iv) Reinforced Cement concrete
  - Foundation
  - Substructure
  - Superstructure – Deck slab & Cross girders
  - Crash barrier/median/footpath/Parapets
- (v) Pre-stressed concrete
  - Longitudinal girders
- (vi) Steel
  - Reinforcement
    - Superstructure
    - Substructure
    - Foundation
  - Pile liner plate
- (vii) Traffic Signages, Road Marking and other Appurtenances
- (viii) Electrical works
- (ix) Miscellaneous items
  - Bearings
  - Expansion joints
  - RE wall structure
  - Drainage spouts

## B. Rates Analysis

105. The unit rates shall be arrived by considering the basic rates, lead distances, man power, machinery, and materials. The unit rate for every individual item will be arrived based on MORTH schedule of rates applicable and standard schedule of rates for Uttar Pradesh for the district Gaziabad 2008. For items of work with no rates specified in the schedule of rates, market rates are obtained and used.

## C. Estimated Costs

106. Costs summary of the proposed project of flyover construction at Mohan Nagar is present in the following **Table 6-1**. The total cost is estimated as INR 513.5 million.

**Table 6-1:** Summary of Cost Estimates

Bill No.	Bill name	Amount (INR)
1	Site Clearance and Dismantling	168,394.00
2	Earthwork	4,768,367.00
3	Sub-base and Base-courses	30,497,551.00
4	Bituminous Works	27,862,232.00
5	Flyover	422,521,116.00
6	Traffic Signages, Road Marking and Other Appurtenances	950,674.00
7	Drainage and Protective Works, Ducts & Other Services	22,552,630.00
8	Electrical Works	4,165,144.00
	Total Construction Cost	513,486,108.00

107. Detailed item-wise estimated, bill of quantities and rate analysis is presented in **Volume V-A4: Detailed Estimates**.

## APPENDICES

**PART-I**

**GEOTECHNICAL INVESTIGATION WORK FOR  
PROPOSED FLYOVER AT MOHAN NAGAR**

**CONTENTS**

SL. No.	CHAPTER	PAGE NO.
1.0	Findings	20-24
1.3	Computations of Safe /Allowable Bearing Capacity	24-25
1.4	Conclusion with Recommendations	25-26
	Bore Log Tables	27-30
	SPT Curves	31-34
	Grain Size Curves	35-38
	Sample Calculation	39-40
	Subsoil Profile	41
	Chemical Test on ground water	42
	Chemical Test on subsoil sample	43

## REPORT ON GEOTECHNICAL & MATERIAL INVESTIGATION

### Summary of Borehole:

Sl. No.	Bore Hole No.	Ground R.L.	Depth of Overburden soil	Total Depth (m)	Depth of Ground Water Table (m)
1.	BH-1	212.105	25.0	25.0	21.0
2.	BH-2	212.108	25.0	25.0	21.0
3.	BH-3	211.995	25.0	25.0	21.0
4.	BH-4	212.094	25.0	25.0	21.0

### **1.0 FINDINGS OF GEOTECHNICAL INVESTIGATION**

**1.1** The classification of subsoil strata met at this site was done according to IS:1498-1970. From the bore logs enclosed with the report, the test results can be summarized as below-

#### **BH-1 (G.R.L. 212.105)**

The subsoil strata from 0.0 to 1.50m depth consists of filled up, from 1.50m to 7.0m, 10.0m to 12.0m & 13.0m to 25.0m depths consist of silty sand classified as SM, from 7.0m to 9.0m & 12.0m to 13.0m depths consist of sandy silt classified as ML and from 9.0m to 10.0m depth consists of sandy silt with clay classified as ML-CL.

#### **BH-2 (G.R.L. 212.108)**

The subsoil strata from 0.0 to 1.50m depth consists of filled up, from 1.50m to 4.0m, 6.0m to 7.0m, 10.0m to 12.0m & 15.0m to 18.0m depths consist of sandy silt classified as ML, from 4.0m to 6.0m, 7.0m 10.0m, 12.0m to 15.0m & 18.0m to 21.0m depths consist of sandy silt with clay classified as ML-CL and from 21.0m to 25.0m depth consists of clayey silt classified as CL.

**BH-3 (G.R.L. 211.995)**

The subsoil strata from 0.0 to 1.50m depth consists of filled up, from 1.50m to 6.0m depth consists of silty sand classified as of SM, from 6.0m to 10.0m, 12.0m to 13.0m & 18.0m to 19.0m depths consist of fine sand classified as SP-SM, from 10.0m to 12.0m & 16.0m to 18.0m depths consist of silty gravels classified as GM, from 13.0m to 15.0m depth consists sandy silt classified as ML, from 15.0m to 16.0m & 19.0m to 21.0m depths consist of sandy silt with clay classified as ML-CL and from 21.0m to 25.0m depth consists of silty sand with gravels classified as SM.

**BH-4 (G.R.L. 212.094)**

The subsoil strata from 0.0 to 8.0m & 20.0m to 24.0m depths consists of silty sand classified as of SM, from 8.0m to 17.0m & 24.0m to 25.0m depths consist of sandy silt classified as ML, from 17.0m to 20.0m depth consists silty gravels classified as GM.

In general the subsoil strata at this site comprise of silty sand and sandy silt below filled up layer. Thin Layers of sandy silt with clay, clayey silt, fine sand and silty gravels are also present at different depths.

the subsoil strata are medium dense to dense up to the depth of exploration.

The Detail description of subsoil strata encountered along with various laboratory test results are presented in the respective bore log enclosed with this report.

The subsoil profile depicting the distribution of the various subsoil strata along with N values (observed/corrected) and other strength parameters with depth are given in subsoil profile enclosed with this report. The SPT Curves (No/Nc), Grain Size Analysis Curves etc. are enclosed with this report.

The layer wise properties of the encountered subsoil strata at this site may be adopted from the following table no. 1.

**Table no.1 layer wise properties of subsoil strata at the site**

Sl. No.	Depth (m)		c	$\phi$	$\gamma_{eff}$	$K_0$	Ka	Kp
	From	To	Kg/cm <sup>2</sup>	degree	gm/cc			
1.	0.0	3.0	0.05	29.0	1.60	0.515	0.347	2.88

**REPORT ON GEOTECHNICAL &  
MATERIAL INVESTIGATION**

2.	3.0	7.0	0.05	30.5	1.65	0.492	0.327	3.06
3.	7.0	16.0	0.0	31.5	1.68	0.477	0.314	3.19
4.	16.0	18.0	0.0	33.5	1.98	0.448	0.289	3.46
5.	18.0	21.0	0.0	33.5	1.0	0.448	0.289	3.46
6.	21.0	25.0	0.0	33.0	1.0	0.455	0.295	3.39

Where

C &  $\phi$  – Shear Parameters

$K_0$ ,  $K_a$ ,  $K_p$  – Earth Pressure Coefficients at rest, in active case & in passive Case.

The depth wise lowest SPT values 'N' (observed/corrected) at the site may be adopted from the following table no.2

**Table No.2 Depth wise lowest observed/corrected SPT Values at the site**

Sl. No.	Depth below existing ground level (m)	Lowest SPT Values		Effective density gm/cc
		Observed	Corrected	
1	1.5	10	14.8	1.60
2	3.0	18	22.4	1.65
3	4.5	18	19.9	1.65
4	6.0	20	20.2	1.65
5	7.5	26	24.2	1.68
6	9.0	21	18.3	1.68
7	10.5	25	20.4	1.68
8	12.0	26	20.1	1.68
9	13.5	28	20.5	1.68
10	15.0	27	18.8	1.68
11	16.5	35	23.0	1.98
12	18.0	42	26.2	1.98

**REPORT ON GEOTECHNICAL &  
MATERIAL INVESTIGATION**

13	19.5	48	21.8	1.98
14	21.0	51	22.3	1.0
15	22.5	56	23.3	1.0
16	24.0	54	22.4	1.0
17	25.0	68	26.0	1.0

The results of chemical analysis of subsoil sample are enclosed with this report.

The result of chemical analysis of subsoil sample indicate that the pH value, sulphate content, chloride content are within permissible limit and the RCC work prepared with Ordinary Portland Cement shall not be deteriorated when placed over/within site subsoil.

The result of chemical analysis tests on ground water sample is annexed with the report.

The results indicate that the pH Value & Sulphate Contents are within permissible limits, the chloride content is on higher sides hence as per IS: 456, at the time of placing the concrete it should be ensured that total amount of chloride (Cl) of all constituents of concrete shall be as per Table 7 of IS;456-2000.

## **1.2 GROUND WATER**

The ground water table was encountered at 21.0m depth below existing ground level in the borehole during boring activities at site. The measured ground water level may fluctuate due to variation in climatic conditions and rate of surface evaporation. However, for design purposes the ground water table may be considered at 15.0m depth below general existing ground level as the ground water level may rise in heavy rainy season/due to unforeseen reasons.

Depending upon the visual examination of soil & field strata, field and laboratory test results and the type of structure proposed at this site The most feasible subsoil-foundation system for proposed structure at this site shall be Normal Bored Cast in Situ RCC Pile Foundations. The details of these pile foundations are given as follows:

- a) Normal Bored Cast in Situ RCC Piles of 1.0m & 1.2m diameter and of 15.0m, 18.0m, & 20.0m lengths below cut-off level with cut-off level at 2.0m below existing ground level.

### **1.3 COMPUTATION OF SAFE LOAD CAPACITY OF NORMAL BORED CAST IN SITU RCC PILE**

The vertical safe load capacity of the Normal Bored Cast in situ pile foundations may be computed as per IRC-78,2000 and IS:2911,Pt-I,sec-2-1979 using following expression:

$$Q_u = Q_p + Q_f$$

$$Q_p = A_p \cdot (c \cdot N_c + \frac{1}{2} \gamma_{eff} \cdot D \cdot N_r + PD \cdot N_q)$$

n

$$Q_f = \sum_{i=1}^n (A_{si} K_i \cdot P_{di} \cdot \tan \delta_i + \alpha_i \cdot c_i)$$

Where,  $A_p$  = Cross sectional area of pile toe.

$D$  = Stem diameter.

$N_c, N_q, N_r$  = Bearing Capacity factors.

$\gamma_{eff}$  = Effective unit weight of soil at pile toe.

$PD$  = Effective overburden pressure at pile toe

$A_{si}$  = Surface area of pile stem for  $i$ th layer.

$K_i$  = Coefficient of earth pressure.

$P_{di}$  = Effective overburden pressure at center of the  $i$ th layer

$\delta$  = Angle of wall friction between soil & pile.

Soil Parameter adopted:

F.O.S. = 3.0 in comp. & =2.5 in uplift

## REPORT ON GEOTECHNICAL & MATERIAL INVESTIGATION

$$\text{and } Q_a, \text{ comp.} = (Q_p + Q_f)/3.0$$

$$Q_a, \text{ uplift} = 0.5 \times Q_f / 2.5$$

The safe lateral load capacity have been computed as per IS: 2911, Pt-I, sec-2-1979 as explained in annexed sample calculation.

### **1.4 CONCLUSION WITH RECOMMENDATIONS:**

On the basis of above Geotechnical investigation the following recommendations are suggested:

4.1 The subsoil strata have been described in detail in clause 1.0.

The safe load capacity of proposed Normal Bored Cast in situ RCC pile may be adopted from the following table for design purposes.

Dia of Pile (m)	Cut-off Level below existing ground (m)	Length of Pile below cutoff (m)	Safe Load Capacity of Pile (T)		
			In Compression	In Uplift	In Lateral Thrust
1.0	2.0	15.0	256.1	92.8	13.9
1.0	2.0	18.0	319.1	127.6	13.9
1.0	2.0	20.0	365.3	153.4	13.9
1.2	2.0	15.0	332.3	111.4	18.7
1.2	2.0	18.0	398.5	161.3	18.7
1.2	2.0	20.0	452.0	191.4	18.7

However before adopting the above values of safe load capacity of pile foundation for design purposes, these should be confirmed through Pile Load Tests at site as per IS: 2911.

**1.5** The ground water table was encountered at 21.0m depth below existing ground level in the boreholes during boring activities at site. The measured ground

## REPORT ON GEOTECHNICAL & MATERIAL INVESTIGATION

water level may fluctuate due to variation in climatic conditions and in the rate of surface evaporation. However, for design purposes the ground water table may be considered at 15.0m depth below existing ground level as the ground water level may rise in heavy rainy season/due to unforeseen reasons.

The result of chemical analysis of subsoil sample indicate that the pH value, sulphate content, chloride content are within permissible limit and the RCC work prepared with Ordinary Portland Cement shall not be deteriorated when placed over/within site subsoil.

The results of chemical analysis on ground water indicate that the pH Value & Sulphate Contents are within permissible limits, the chloride content is on higher sides hence as per IS: 456, at the time of placing the concrete it should be ensured that total amount of chloride (Cl) of all constituents of concrete shall be as per Table 7 of IS:456-2000.

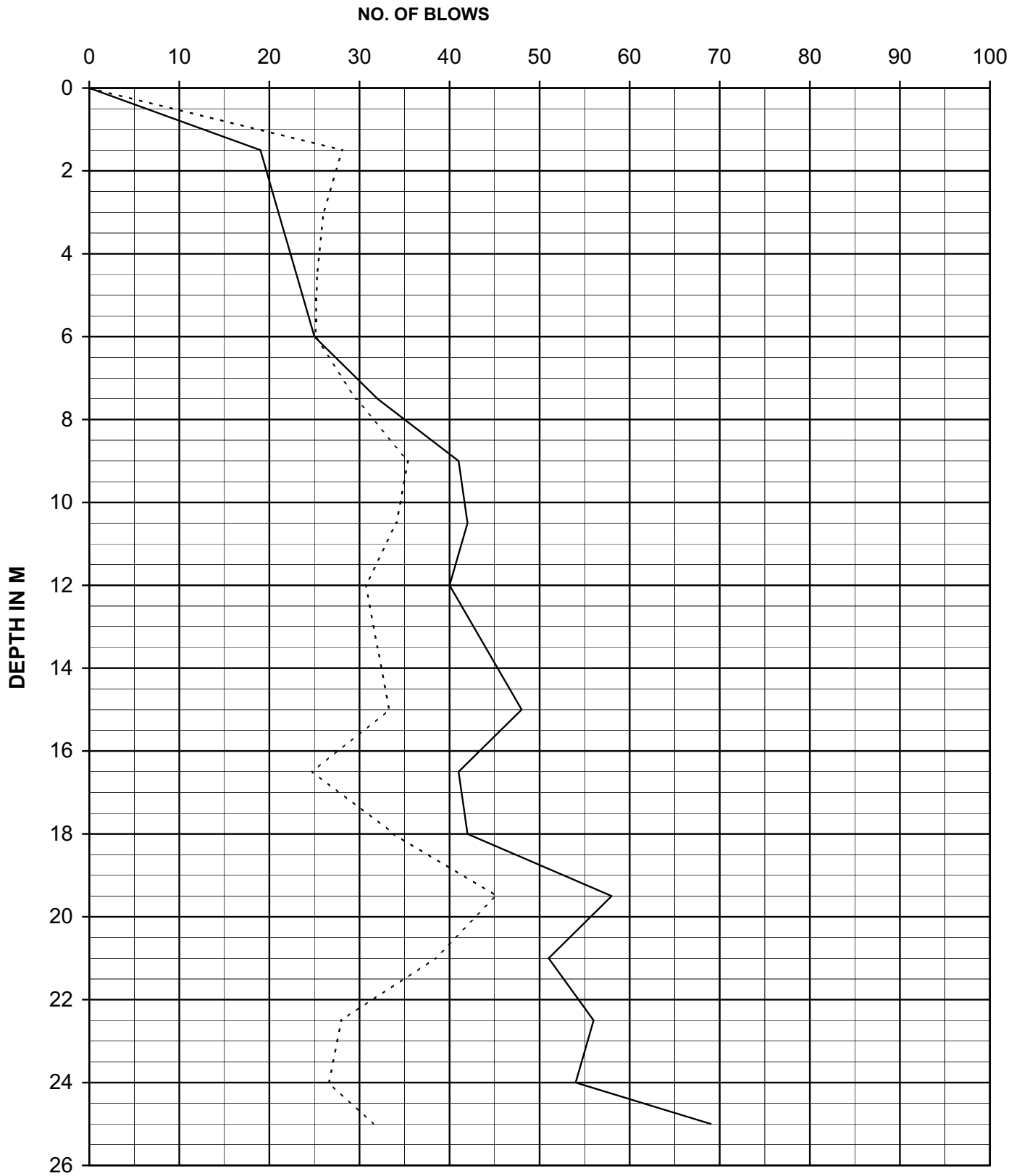
1.6 The layer wise properties of subsoil strata may be adopted from table no.1 & 2.0 of clause 1.0.

					<b>SOIL PROFILE</b>	<b>PROJECT: GEOTECHNICAL INVESTIGATION WORK FOR FLYOVER AT MOHAN NAGAR</b>								<b>SHEET NO 27</b>			
					<b>GROUND R.L.</b>	<b>BOREHOLE NO</b>	<b>BORING DATE</b>		<b>TERMINAL DEPTH (m)</b>				<b>WATER TABLE (m)</b>				
					212.105	BH-1	09/09 TO 11/09/2009		25.00				21.00				
N VALUES	R.L.	DEPTH m	SAMPLE	DESCRIPTION OF SOIL	IS CLASSIFICATION	GRAIN SIZE ANALYSIS				LIQUID LIMIT	PLASTIC LIMIT	DRY/BULK DENSITY	MOIST. CONT	SHEAR PARAMETER			SPECIFIC GRAVITY
						GRAVEL %	SAND %	SILT %	CLAY %	%	%	gm/cc	%	TEST TYPE	C kg/cm <sup>2</sup>	φ deg.	
19	211.605	0.5	DS-1	Filled up													
	210.605	1.5	SPT-1														
	209.605	2.5	UDS-1	Silty Sand	SM	7	60	38	0	N	P	1.56/1.62	4.15	DST	0.05	30.5	2.64
21	209.105	3.0	SPT-2														
23	207.605	4.5	SPT-3														
	207.105	5.0	UDS-2	Silty Sand	SM	6	55	39	0	N	P	1.61/1.68	4.26	DST	0.05	30.5	2.65
25	206.105	6.0	SPT-4														
32	204.605	7.5	SPT-5														
	204.105	8.0	UDS-3	Sandy silt	ML	2	35	58	5	20	17	1.66/1.74	5.12	DST	0.10	31.0	2.66
41	203.105	9.0	SPT-6	Sandy silt with clay	ML-CL	3	20	67	10	28	21						2.68
42	201.605	10.5	SPT-7														
	201.105	11.0	UDS-4	Silty Sand	SM	0	57	43	0	N	P	1.68/1.77	5.64	DST	0.05	32.5	2.64
40	200.105	12.0	SPT-8	Sandy silt	ML	0	44	56	0								
44	198.605	13.5	SPT-9														
	198.105	14.0	UDS-5	Silty Sand	SM	0	56	44	0	N	P	1.68/1.78	5.82	DST	0.0	33.5	2.65
48	197.105	15.0	SPT-10														
41	195.605	16.5	SPT-11														
	195.105	17.0	UDS-6	Silty Sand	SM	0	55	45	0	N	P	1.64/1.76	7.16	DST	0.0	33.5	2.65
42	194.105	18.0	SPT-12														
58	192.605	19.5	SPT-13														
	192.105	20.0	UDS-7	Silty Sand	SM	0	54	46	0	N	P	1.65/1.85	9.26	DST	0.0	33.0	2.65
51	191.105	21.0	SPT-14														
56	189.605	22.5	SPT-15														
	189.105	23.0	UDS-8							Slipped							
54	188.105	24.0	SPT-16														
69	187.105	25.0	SPT-17	Silty Sand	SM	0	54	46	0	N	P			DST	0.0	33.0	2.65





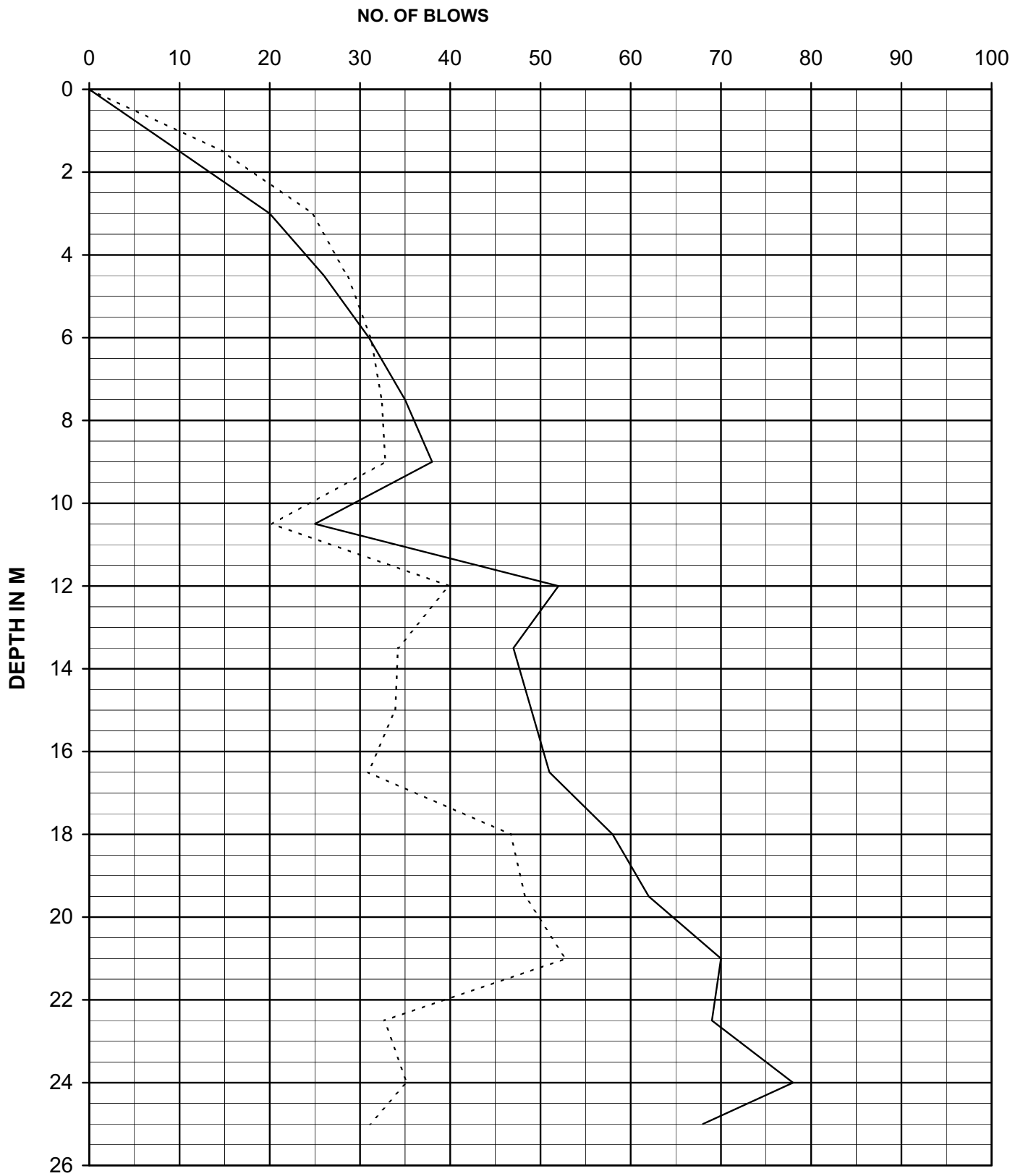
					SOIL PROFILE	PROJECT: GEOTECHNICAL INVESTIGATION WORK FOR FLYOVER AT MOHAN NAGAR								SHEET NO 30			
					GROUND R.L.	BOREHOLE NO		BORING DATE		TERMINAL DEPTH (m)			WATER TABLE (m)				
					212.094	BH-4				25.00			21.00				
N VALUES	R.L.	DEPTH	SAMPLE	DESCRIPTION OF SOIL	IS CLASSIF-ICATION	GRAIN SIZE ANALYSIS				LIQUID LIMIT	PLASTIC LIMIT	DRY/BULK DENSITY	MOIST. CONT	SHEAR PARAMETER		SPECIFIC GRAVITY	
		m				GRAVEL %	SAND %	SILT %	CLAY %	%	%	gm/cc	%	TEST TYPE	C kg/cm <sup>2</sup>	φ deg.	
17	211.594	0.5	DS-1	Silty sand	SM	2	53	45	0	N	P	1.56/1.62	3.76	DST	0.05	30.0	2.65
	210.594	1.5	SPT-1														
	209.594	2.5	UDS-1														
21	209.094	3.0	SPT-2	Silty sand	SM	2	65	33	0	N	P	1.62/1.69	4.17	DST	0.0	32.0	2.64
25	207.594	4.5	SPT-3														
	207.094	5.0	UDS-2														
24	206.094	6.0	SPT-4	Sandy silt	ML	4	38	58	0	N	P	1.64/1.72	5.08	DST			2.66
26	204.594	7.5	SPT-5														
	204.094	8.0	UDS-3														
29	203.094	9.0	SPT-6	Sandy silt	ML	3	34	59	4	21	18	1.66/1.75	5.72	DST	0.10	31.0	2.65
26	201.594	10.5	SPT-7														
	201.094	11.0	UDS-4														
30	200.094	12.0	SPT-8	Sandy silt	ML	3	36	61	0	N	P	1.65/1.75	5.86	DST			2.65
	198.594	13.5	SPT-9														
	198.094	14.0	UDS-5														
35	197.094	15.0	SPT-10	Silty gravels	GM	12	30	58	0	N	P	1.68/1.80	7.36	DST	0.0	33.5	2.68
35	195.594	16.5	SPT-11														
	195.094	17.0	UDS-6														
47	194.094	18.0	SPT-12	Silty sand	SM	7	52	41	0	N	P	1.72/1.98	15.22	DST	0.0	33.5	2.68
48	192.594	19.5	SPT-13														
	192.094	20.0	UDS-7														
54	191.094	21.0	SPT-14	Silty sand	SM	5	53	42	0	N	P	1.74/2.02	16.14	DST	0.15	34.0	2.64
61	189.594	22.5	SPT-15														
	189.094	23.0	UDS-8														
70	188.094	24.0	SPT-16	Sandy silt	ML	0	42	58	0	N	P						2.65
73	187.094	25.0	SPT-17														



SPT CURVE

BH-1

Continuous line - Observed SPT, Dotted Line - Corrected SPT

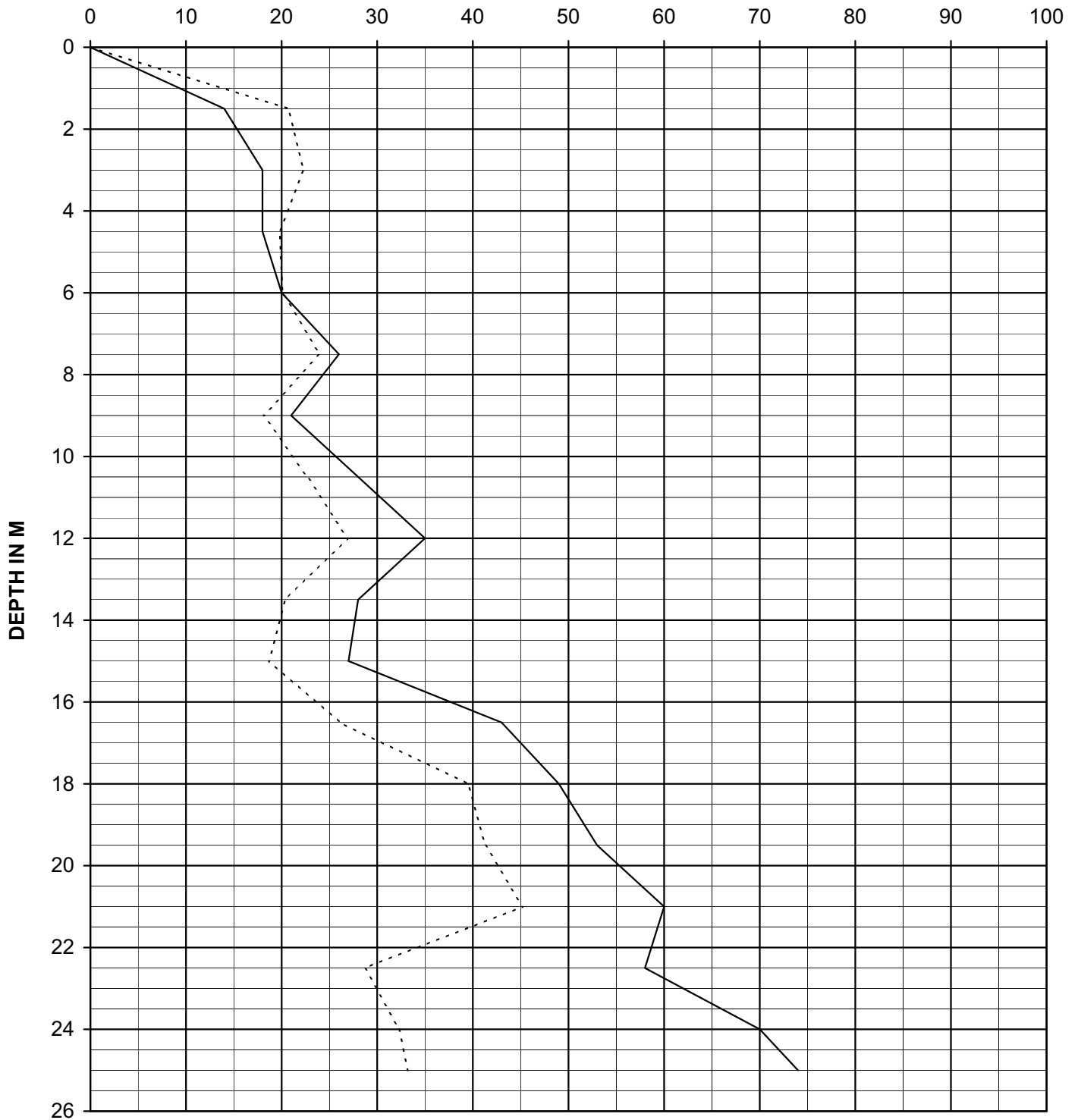


SPT CURVE

BH-2

Continuous line - Observed SPT, Dotted Line - Corrected SPT

NO. OF BLOWS

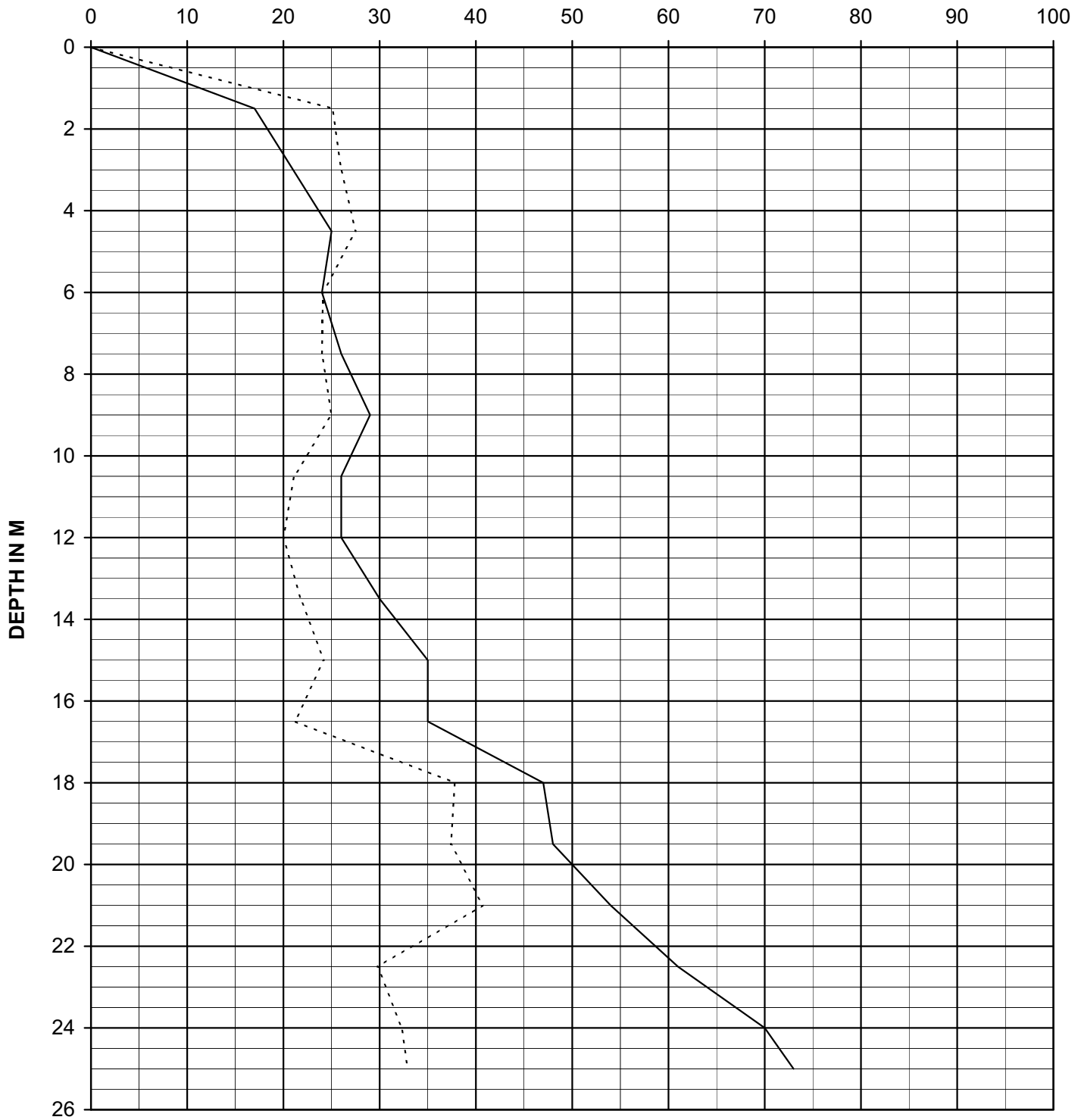


SPT CURVE

BH-3

Continuous line - Observed SPT, Dotted Line - Corrected SPT

NO. OF BLOWS



SPT CURVE

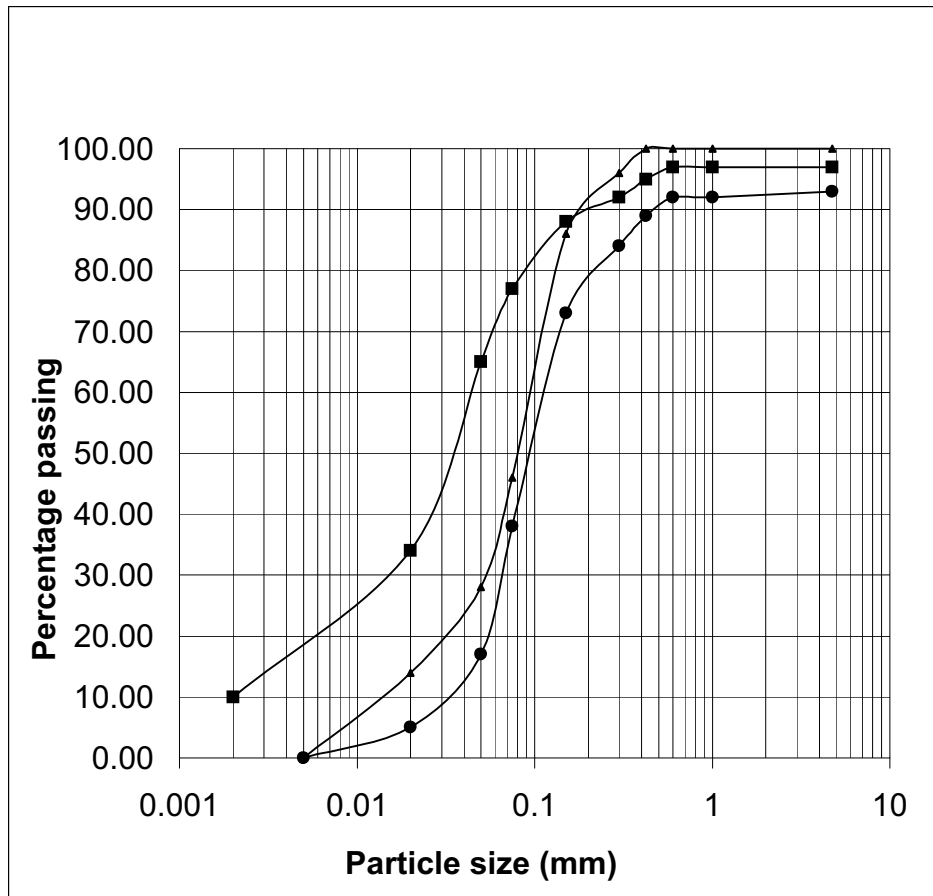
BH-4

Continuous line - Observed SPT, Dotted Line - Corrected SPT

## GRAIN SIZE ANALYSIS

Project: GEOTECHNICAL Investigation for FLYOVER at Mohan Nagar

Bore Hole No. BH - 1

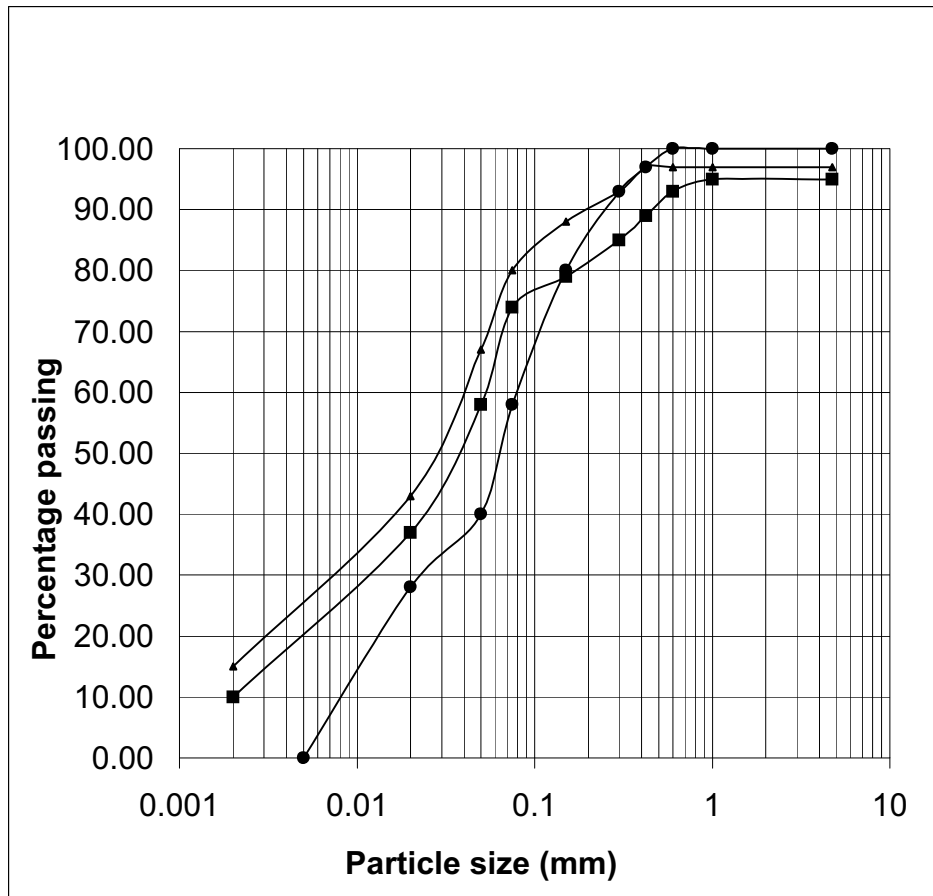


Symbol	Description of soil	Depth (m)	Gravel (%)	Sand (%)	Silt (%)	Clay (%)
●	Silty sand	2.50	7	60	38	0
■	Sandy silt with clay	9.00	3	20	67	10
▲	Silty sand	20.00	0	54	46	0

## GRAIN SIZE ANALYSIS

Project: GEOTECHNICAL Investigation for FLYOVER at Mohan Nagar

Bore Hole No. BH - 2

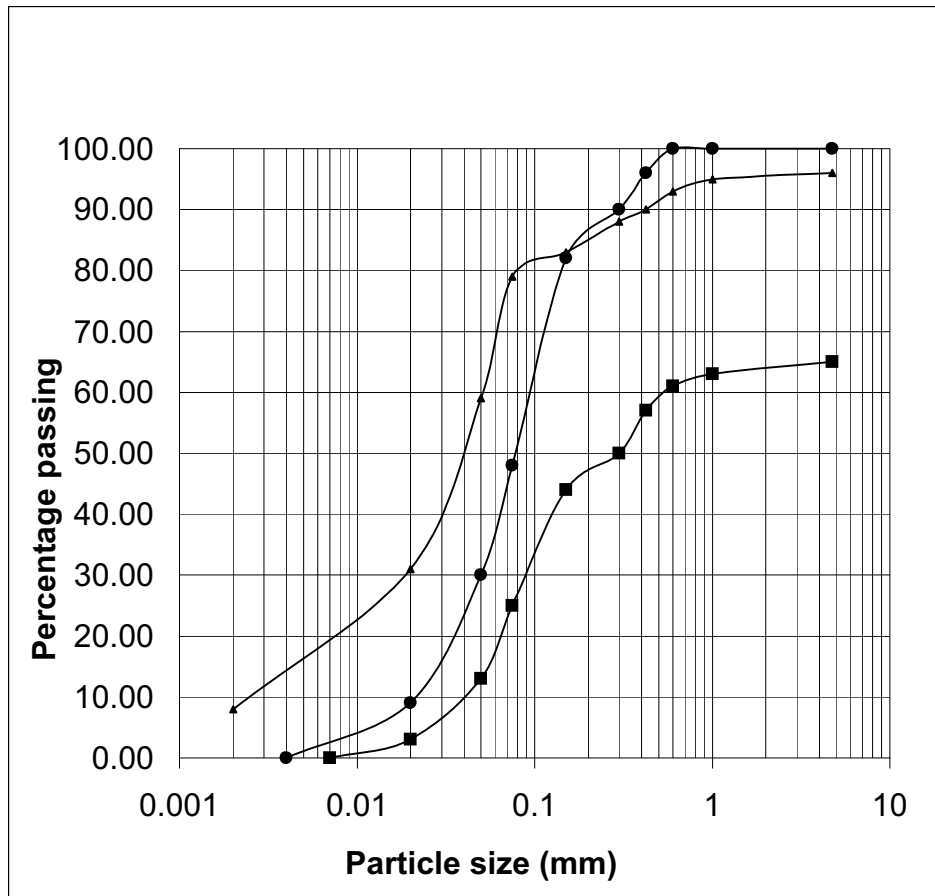


Symbol	Description of soil	Depth (m)	Gravel (%)	Sand (%)	Silt (%)	Clay (%)
●	Sandy silt	2.50	0	42	58	0
■	Sandy silt with clay	14.00	5	21	64	10
▲	Clayey silt	23.00	3	17	65	15

## GRAIN SIZE ANALYSIS

Project: GEOTECHNICAL Investigation for FLYOVER at Mohan Nagar

Bore Hole No. BH - 3

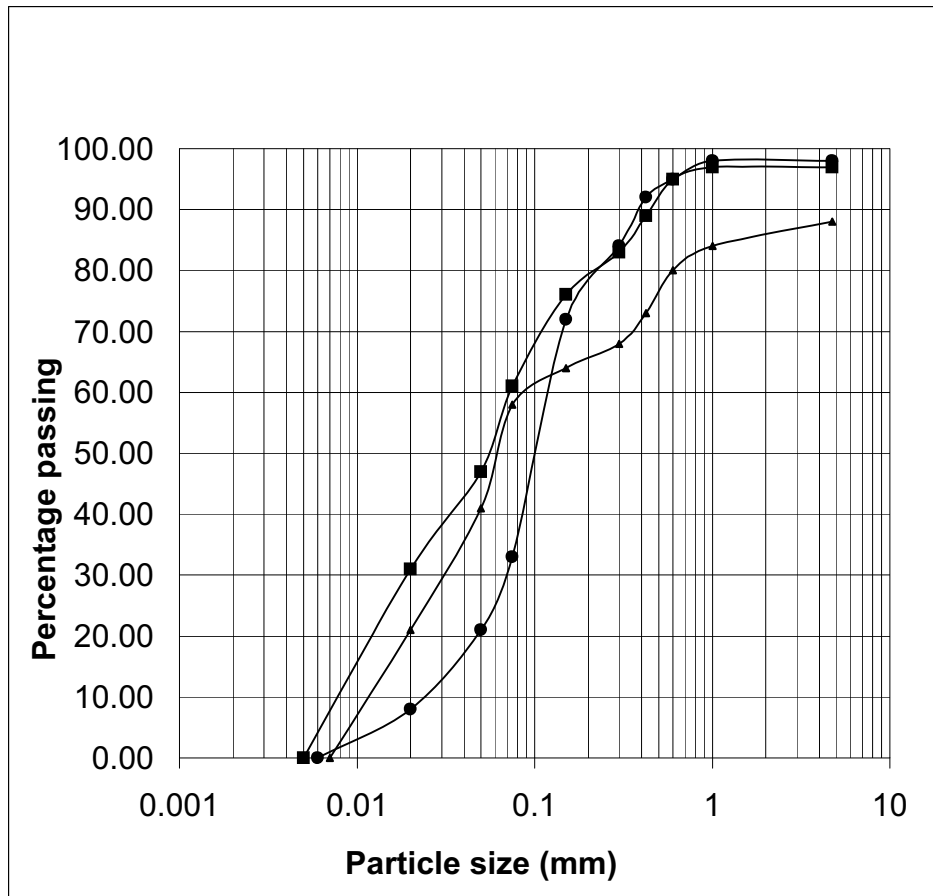


Symbol	Description of soil	Depth (m)	Gravel (%)	Sand (%)	Silt (%)	Clay (%)
●	Silty sand	2.50	0	52	48	0
■	Silty gravels	11.00	35	40	25	0
▲	Sandy silt with clay	20.00	4	17	71	8

## GRAIN SIZE ANALYSIS

Project: GEOTECHNICAL Investigation for FLYOVER at Mohan Nagar

Bore Hole No. BH - 4



Symbol	Description of soil	Depth (m)	Gravel (%)	Sand (%)	Silt (%)	Clay (%)
●	Silty sand	5.00	2	65	33	0
■	Sandy silt	14.00	3	36	61	0
▲	Silty gravels	17.00	12	30	58	0

**SAMPLE CALCULATION FOR SAFE LATERAL LOAD CAPACITY OF BORED CAST IN SITU RCC PILE FOUNDATION (AS PER:2911,Pt-I,sec-2-1979)**

**Location: Geotechnical Investigation for Flyover at Mohan Nagar**

**The safe Lateral load carrying capacity of Normal bored Cast in situ RCC piles have been calculated using the following expression: -**

$$T = 5\sqrt{E.I/K_1} \dots\dots 1$$

Where,  $K_1$  is constant given in table 1, appendix-c, of above code

'E' is Young's modulus of the pile material in  $\text{kg/cm}^2$

'I' is the moment of inertia of the pile cross section in  $\text{cm}^4$

As per IS: 456, 2000  $E = 5000\sqrt{f_{ck}}$

Where  $f_{ck}$  is the characteristic strength of concrete of pile

Considering  $f_{ck} = 35 \text{ N/mm}^2$   $E = 5000\sqrt{35} = 29580.4 \text{ N/mm}^2$   
 $= 295804.0 \text{ Kg/cm}^2$

For Dia of pile, 'D' = 120cm,  $I = \frac{\pi}{64} \times (120)^4$   
 $= 10182857 \text{ cm}^4$

$$K_1 = 0.146$$

( for loose submerged case in worst subsoil condition.

Putting these values into the above equation-1, we get

$$T = 460.16 \text{ cm}$$

From fig.2, appendix-c of above code for fixed head pile and  $L_1 = 0.0$ ,  $L_f/T = 2.15$

$$\text{Or } L_f = 460.16 \times 2.15 = 989.3 \text{ cm}$$

And from equation,  $Y = Q(L_1 + L_f)^3 / 12EI$ , where Q is lateral load in kg

Adopting  $Y = 5 \text{ mm} = 0.5 \text{ cm}$ , we have

$$0.5 = Q(0.0 + 989.3)^3 / (12 \times 295804.0 \times 10182857)$$

$$\text{Or } Q_l = 18,666 \text{ kg} = 18.7 \text{ T}$$

**As per above analysis, the safe lateral load capacity of subject pile may be adopted as 18.7 T.**

### SAMPLE CALCULATION FOR VERTICAL SAFE LOAD CAPACITY OF BORED CAST IN SITU RCC PILE FOUNDATION (AS PER IRC-78, 2000)

Location: Geotechnical Investigation Flyover at Mohan Nagar

The safe vertical load carrying capacity of Normal bored Cast in situ RCC piles have been calculated using the following expression: -

$$Q_u = A_p (c.N_c + \frac{1}{2} r D N_r + PD N_q) + \sum_{i=1}^n (A_{si} K_i P_{di} \tan \delta + \alpha_i c_i)$$

where,  $A_p$  = Cross sectional area of pile toe.

$D$  = Stem diameter.

$N_c, N_q, N_r$  = Bearing Capacity factors.

$r$  = Effective unit weight of soil at pile toe.

$PD$  = Effective overburden pressure at pile toe

$A_{si}$  = Surface area of pile stem for  $i$ th layer.

$K_i$  = Coefficient of earth pressure = 1.5

$P_{di}$  = Effective overburden pressure at center of the  $i$ th layer

$\delta$  = Angle of wall friction =  $\emptyset$

Ground water has been assumed at 15.0m depth.

Soil Parameter adopted:

Depth (m)		$\gamma$	$c$	$\phi$	$k$	$\delta$	$\alpha$
From	To	T/m <sup>3</sup>	Kg/cm <sup>2</sup>	degree		degree	
0.0	3.0	1.60	0.0	28	1.5	28	0.0
2.0	3.0	1.60	0.0	28	1.5	28	0.0
3.0	7.0	1.65	0.0	28	1.5	28	0.0
7.0	15.0	1.0	0.0	28	1.5	28	0.0
15.0	25.0	1.0	0.0	28	1.5	28	0.0

\*During piling process the cohesion less strata get loosened hence properties of loose sand i.e.  $C = 0.0 \text{ kg/cm}^2$ ,  $\phi = 28.0^\circ$  have been adopted.

For pile dia= 1.20m, cut off level below EGL = 2.0 m

and length of pile= 18.0m

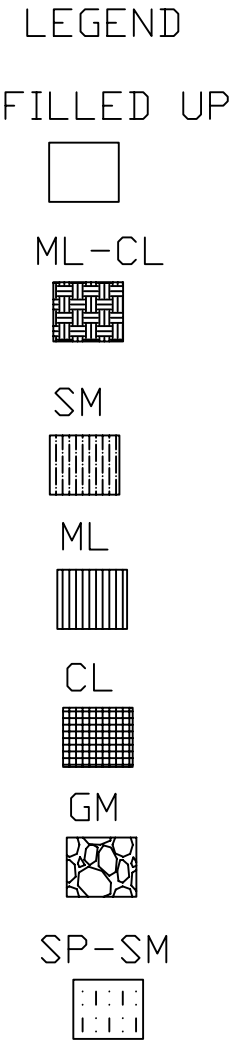
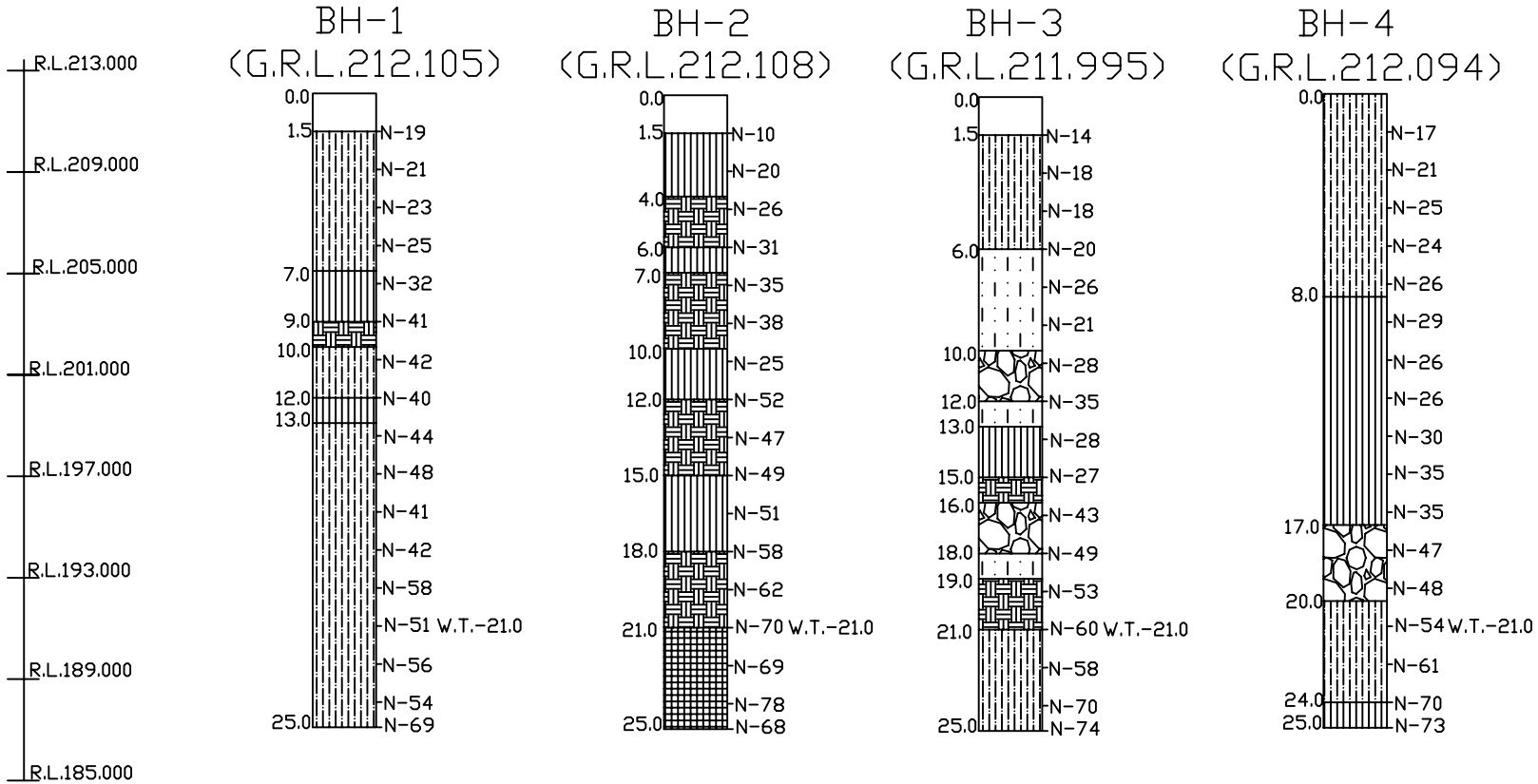
$P_D = 2.664 \text{ kg/cm}^2$ ,  $N_c = 0.0$ ,  $N_q = 16$ ,  $N_r = 17.792$ , F.O.S. = 3.0 in comp. & =2.5 in uplift

Applying above parameters in above equation, we get

$$Q_u = Q_p + Q_f = 374.1 + 821.0 \text{ T and } Q_a, \text{ comp.} = (374.1 + 821.0)/3.0 = 398.4 \text{ T}$$

$$Q_a, \text{ uplift} = 0.5 \times 821/2.5 - \text{uplift pressure of ground water} \\ = 164.2 - 5.0 = 159.2$$

(uplift pressure of ground water = cut off level + length of pile – assumed ground water depth)



SUBSOIL PROFILE

Geotechnical Investigation work for Flyover at Mohan Nagar

**CHEMICAL TEST REPORT OF GROUND WATER SAMPLE****Location: Geotechnical Investigation for flyover at Mohan Nagar****SAMPLE NO: 1****BORE HOLE NO: BH-1**

<b>SL.NO.</b>	<b>Name of test</b>	<b>Observed values</b>	<b>Permissible values</b>
<b>1</b>	<b>pH value</b>	<b>6.8</b>	<b>&gt;6</b>
<b>2</b>	<b>Chloride content</b>	<b>624mg/l</b>	<b>500 mg/l</b>
<b>3</b>	<b>Sulphate content (as SO<sub>3</sub><sup>2-</sup>)</b>	<b>51.7mg/l</b>	<b>400 mg/l</b>

**CHEMICAL TEST REPORT OF SUBSOIL SAMPLE****Location: Geotechnical Investigation for flyover at Mohan Nagar****SAMPLE NO: 1****BORE HOLE NO: BH-4****DEPTH: 4.5m**

<b>SL.NO.</b>	<b>Name of test</b>	<b>Observed values</b>	<b>Permissible values</b>
<b>1</b>	<b>pH value</b>	<b>6.9</b>	<b>&gt;6</b>
<b>2</b>	<b>Chloride content</b>	<b>0.012%</b>	<b>0.2%</b>
<b>3</b>	<b>Sulphate content (as SO<sub>3</sub><sup>2-</sup>)</b>	<b>0.062%</b>	<b>0.16 %</b>